



Service Manual

Lexmark Optra™ K

4046

- ***Table of Contents***
- ***Start Diagnostics***
- ***Safety and Notices***
- ***Trademarks***
- ***Index***
- ***Manuals Menu***

LEXMARK™

Lexmark and Optra are trademarks of Lexmark International, Inc., registered in the United States and/or other countries.

Second Edition (October 1998)

The following paragraph does not apply to any country where such provisions are inconsistent with local law: LEXMARK INTERNATIONAL, INC. PROVIDES THIS PUBLICATION "AS IS" WITHOUT WARRANTY OF ANY KIND, EITHER EXPRESS OR IMPLIED, INCLUDING, BUT NOT LIMITED TO, THE IMPLIED WARRANTIES OF MERCHANTABILITY OR FITNESS FOR A PARTICULAR PURPOSE. Some states do not allow disclaimer of express or implied warranties in certain transactions, therefore, this statement may not apply to you.

This publication could include technical inaccuracies or typographical errors. Changes are periodically made to the information herein; these changes will be incorporated in later editions. Improvements or changes in the products or the programs described may be made at any time. Publications are not stocked at the address given below; requests for publications should be made to your point of purchase.

A form for reader's comments is provided at the back of this publication. If the form has been removed, comments may be addressed to Lexmark International, Inc., Department D22A/035-3, 740 New Circle Road NW, Lexington, Kentucky 40550, U.S.A. Lexmark may use or distribute any of the information you supply in any way it believes appropriate without incurring any obligation to you.

Lexmark and Optra are trademarks of Lexmark International, Inc., registered in the United States and/or other countries.

Other trademarks are the property of their respective owners.

© Copyright Lexmark International, Inc. 1998. All rights reserved.

UNITED STATES GOVERNMENT RESTRICTED RIGHTS

This software and documentation are provided with RESTRICTED RIGHTS. Use, duplication or disclosure by the Government is subject to restrictions as set forth in subparagraph (c)(1)(ii) of the Rights in Technical Data and Computer Software clause at DFARS 252.227-7013 and in applicable FAR provisions: Lexmark International, Inc., Lexington, KY 40550.

Contents

Notices and Safety Information	vii
Laser Notice	vii
Laser Advisory Label	viii
Class 1 Laser Statement Label	viii
General Information	1-1
Maintenance Approach	1-1
Tools	1-1
Abbreviations	1-2
Mechanical Operation	1-3
System Diagram	1-4
Printer Operation	1-5
Paper Feed Drive Mechanism	1-5
Process Drive Mechanism	1-7
Print Unit	1-7
Fuser	1-8
Paper Ejection	1-8
Diagnostic Information	2-1
Start	2-2
Initial Check	2-2
Service Error Code Table	2-3
User Error Messages	2-5
Symptom Table	2-8
Service Checks	2-9
Cover Open Switch Service Check	2-9
Dead Machine Service Check	2-10
Engine Fan Service Check	2-11
Erase LED Service Check	2-11
Exit Sensor Service Check	2-12
Fuser Service Check	2-13
Image Quality Service Check	2-13
Main Motor Service Check	2-20
Input Sensor Service Check	2-21
Operator Panel Buttons Service Check	2-22
Operator Panel Display Service Check	2-22
Options Service Check	2-23
Paper Feed Service Check	2-24
Parallel Port Service Check	2-26
Printhead Service Check	2-26
Process Fan Service Check	2-27
Serial Port Service Check	2-27

Standard Bin Full Sensor Service Check	2-27
Toner Sensor Service Check	2-29
Transfer Corona Service Check	2-29
Diagnostic Aids	3-1
Diagnostic Mode	3-1
Exiting the Diagnostic Mode	3-1
Power-On Self Test (POST)	3-2
Device Tests	3-2
Quick Disk Test	3-2
Disk Test/Clean	3-3
Flash Test	3-3
Disabling Download Emulations	3-4
Error Log	3-4
Viewing the Error Log	3-4
Clearing the Error Log	3-5
Hardware Tests	3-5
LCD Test	3-5
Button Test	3-6
DRAM Memory Test	3-6
ROM Memory Test	3-6
Parallel Wrap Test	3-7
Serial Wrap Test	3-8
Input Tray Tests	3-10
Input Tray Feed Test	3-10
Input Tray Sensor Test	3-10
Base Sensor Test	3-11
Print Registration	3-11
Printer Setup	3-12
Setting the Page Count	3-12
Viewing the Permanent Page Count	3-13
Setting Configuration ID	3-13
Print Tests	3-14
Print Quality Test Pages	3-14
Printing Menu Settings Page	3-15
Paper Jams - Base Printer	3-16
Paper Jams - Options	3-16
Repair Information	4-1
Precautions for Disassembly and Cleaning	4-1
Instructions for Handling the PWBs with MOS ICs	4-1
Precautions for Handling the Drum Cartridge	4-2
Parts not to be touched	4-2
Precautions for Handling the Laser Equipment	4-3

Removal Procedures	4-4
Control Board Removal	4-4
Cover Removal.	4-5
Cover-Open Switch Removal.	4-7
Engine Board Removal	4-8
Engine Fan Removal	4-9
Exit Paper Feed Roller Assembly Removal	4-10
Fuser Removal.	4-11
High Voltage Power Supply Board and Interconnect Board Removal	4-12
Main Motor Removal	4-14
Multi-Function Feeder Board Removal.	4-16
Paper Feed Motor Removal	4-17
Paper Feed Roller Removal.	4-18
Pick-up Motor Removal	4-22
Pick-up Roller Removal	4-23
Power Supply Board Removal	4-25
Print Density Board Removal.	4-26
Printhead Removal.	4-27
Printhead Erase LED Assembly Removal	4-27
Process Fan Removal	4-28
Separator Assembly Removal	4-30
Stacker Full Sensor Board Removal	4-31
Transfer Corona Removal	4-32
Locations	5-1
Front and Right Side of Printer.	5-1
Rear and Left Side of Printer	5-2
Interior of Printer with Upper Door Open	5-3
Optional Multi-Function Feeder and Paper Feeder	5-4
Sensors	5-5
EP Diagram	5-6
Engine Board	5-7
Control Board.	5-8
Power Supply Board.	5-9
Interconnect Board.	5-10
Parts Catalog	6-1
How to Use This Parts Catalog.	6-1
Upper Cover.	6-2
Covers	6-4
Electronics	6-6
Frame, Left Side.	6-10
Frame, Right Side	6-12

Input Paper Feed	6-14
Printhead and Paper Feed Redrive	6-16
Exit Paper Feed Frame	6-18
Fuser	6-20
Paper Tray, 250 Sheet	6-22
Optional 450 Sheet Second Paper Tray	6-24
Optional 450 Sheet Second Paper Drawer (2)	6-26
Optional 450 Sheet Second Paper Drawer (2)	6-28
Optional Multi-Function Feeder	6-30
Index	x-1

Notices and Safety Information

References in this publication to products, programs, or services do not imply that the manufacturer intends to make these available in all countries in which it operates. Any reference to a product, program, or service is not intended to state or imply that only that product, program, or service may be used. Any functionally equivalent product, program, or service that does not infringe any existing intellectual property rights may be used instead. Evaluation and verification of operation in conjunction with other products, programs, or services, except those expressly designated by the manufacturer, are the user's responsibility.

Laser Notice

The printer is certified in the U.S. to conform to the requirements of DHHS 21 CFR Subchapter J for Class I (1) laser products, and elsewhere is certified as a Class I laser product conforming to the requirements of IEC 825.

Class I laser products are not considered to be hazardous. The printer contains internally a Class IIIb (3b) laser that is nominally a 5 milliwatt gallium arsenide laser operating in the wavelength region of 770-795 nanometers. The laser system and printer are designed so there is never any human access to laser radiation above a Class I level during normal operation, user maintenance, or prescribed service condition.

Laser Advisory Label

Label is inside printer

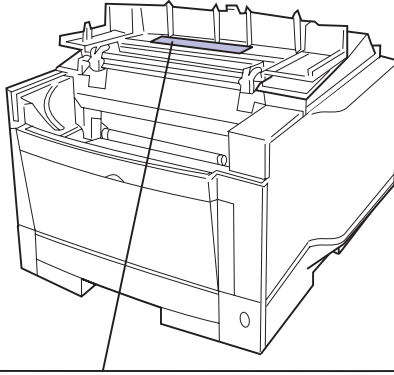

CAUTION -	Invisible laser radiation when open and interlock defeated. Avoid exposure to beam.
ATTENTION -	Radiation laser invisible si le dispositif est ouvert et non bloqué. Évitez l'exposition au rayon.
VORSICHT -	Unsichtbare Laserstrahlung wenn drucker offen und sperre gelöst. Nicht dem strahl aussetzen.
VOORZICHTIG -	Onzichtbare laserstraling wanneer open en niet vergrendeld. Vermijd blootstelling aan straal.
ATTENZIONE -	Radiatori laser invisibili se il dispositivo è aperto e non bloccato. Evitare l'esposizione diretta.
AVISO -	Radiación laser invisible si la cubierta está abierta y el dispositivo no está bloqueado. Evite exponerse a la radiación.
CUIDADO -	Radiación laser invisible quando a tampa é aberta. Evite exposição aos raios.
VARO!	Arvasteassa ja suojalukitus ohitettavissa olet altissima näkyvättömälle laser säteilylle. Älä katso säteeseen.
VARNING -	Osynlig laserstrålning när dörarna är öppna och spärrarna är utslagna. Se till att inte titta in i strålen.
ADVARSEL -	Usynlig laserstråling når dørene åpnes og sikkerhetsdørene er ute av funksjon. Unngå eksponering for stråling.
ADVARSEL -	Usynlig laserstrålning når dörarna är öppna och spärrarna är utslagna. Se till att inte titta in i strålen.
ATENCIÓN -	Radiación laser invisible si s'obren i el tancament intern no és correcte. Eviteu exposar-vos-hi.
注意 -	開閉時有害な不可視レーザー放射線外泄・誘致危険箇所に光線下
注意 -	トナーカートリッジを交換する際、レーザーが作動し、放射線が放出される場合があります。ご注意ください。必ずご注意ください。
주의 -	개방과 인터락이 실패 시 눈에 보이지 않는 레이저가 방사됩니다. 레이저 빛에 노출되지 않도록 하십시오

Class 1 Laser Statement Label

Label is on back of printer.

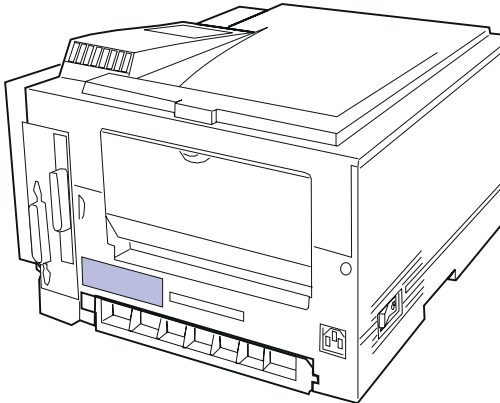

Laser

Der Drucker erfüllt gemäß amtlicher Bestätigung der USA die Anforderungen der Bestimmung DHHS (Department of Health and Human Services) 21 CFR Teil J für Laserprodukte der Klasse I (1). In anderen Ländern gilt der Drucker als Laserprodukt der Klasse I, der die Anforderungen der IEC (International Electrotechnical Commission) 825 gemäß amtlicher Bestätigung erfüllt.

Laserprodukte der Klasse I gelten als unschädlich. Im Inneren des Druckers befindet sich ein Laser der Klasse IIIb (3b), bei dem es sich um einen Galliumarsenlaser mit 5 Milliwatt handelt, der Wellen der Länge 770-795 Nanometer ausstrahlt. Das Lasersystem und der Drucker sind so konzipiert, daß im Normalbetrieb, bei der Wartung durch den Benutzer oder bei ordnungsgemäßer Wartung durch den Kundendienst Laserbestrahlung, die die Klasse I übersteigen würde, Menschen keinesfalls erreicht.

Avis relatif à l'utilisation de laser

Pour les Etats-Unis : cette imprimante est certifiée conforme aux provisions DHHS 21 CFR alinéa J concernant les produits laser de Classe I (1). Pour les autres pays : cette imprimante répond aux normes IEC 825 relatives aux produits laser de Classe I.

Les produits laser de Classe I sont considérés comme des produits non dangereux. Cette imprimante est équipée d'un laser de Classe IIIb (3b) (arséniure de gallium d'une puissance nominale de 5 milliwatts) émettant sur des longueurs d'onde comprises entre 770 et 795 nanomètres. L'imprimante et son système laser sont conçus pour impossible, dans des conditions normales d'utilisation, d'entretien par l'utilisateur ou de révision, l'exposition à des rayonnements laser supérieurs à des rayonnements de Classe I .

Avvertenze sui prodotti laser

Questa stampante è certificata negli Stati Uniti per essere conforme ai requisiti del DHHS 21 CFR Sottocapitolo J per i prodotti laser di classe 1 ed è certificata negli altri Paesi come prodotto laser di classe 1 conforme ai requisiti della norma CEI 825.

I prodotti laser di classe non sono considerati pericolosi. La stampante contiene al suo interno un laser di classe IIIb (3b) all'arseniuro di gallio della potenza di 5mW che opera sulla lunghezza d'onda compresa tra 770 e 795 nanometri. Il sistema laser e la stampante sono stati progettati in modo tale che le persone a contatto con la stampante, durante il normale funzionamento, le operazioni di servizio o quelle di assistenza tecnica, non ricevano radiazioni laser superiori al livello della classe 1.

Avisos sobre el láser

Se certifica que, en los EE.UU., esta impresora cumple los requisitos para los productos láser de Clase I (1) establecidos en el subcapítulo J de la norma CFR 21 del DHHS (Departamento de Sanidad y Servicios) y, en los demás países, reúne todas las condiciones expuestas en la norma IEC 825 para productos láser de Clase I (1).

Los productos láser de Clase I no se consideran peligrosos. La impresora contiene en su interior un láser de Clase IIIb (3b) de arseniuro de galio de funcionamiento nominal a 5 milivatios en una longitud de onda de 770 a 795 nanómetros. El sistema láser y la impresora están diseñados de forma que ninguna persona pueda verse afectada por ningún tipo de radiación láser superior al nivel de la Clase I durante su uso normal, el mantenimiento realizado por el usuario o cualquier otra situación de servicio técnico.

Declaração sobre Laser

A impressora está certificada nos E.U.A. em conformidade com os requisitos da regulamentação DHHS 21 CFR Subcapítulo J para a Classe I (1) de produtos laser. Em outros locais, está certificada como um produto laser da Classe I, em conformidade com os requisitos da norma IEC 825.

Os produtos laser da Classe I não são considerados perigosos. Internamente, a impressora contém um produto laser da Classe IIIb (3b), designado laser de arseneto de potássio, de 5 milliwatts, operando numa faixa de comprimento de onda entre 770 e 795 nanómetros. O sistema e a impressora laser foram concebidos de

forma a nunca existir qualquer possibilidade de acesso humano a radiação laser superior a um nível de Classe I durante a operação normal, a manutenção feita pelo utilizador ou condições de assistência prescritas.

Laserinformatie

De printer voldoet aan de eisen die gesteld worden aan een laserprodukt van klasse I. Voor de Verenigde Staten zijn deze eisen vastgelegd in DHHS 21 CFR Subchapter J, voor andere landen in IEC 825.

Laserprodukten van klasse I worden niet als ongevaarlijk aangemerkt. De printer is voorzien van een laser van klasse IIIb (3b), dat wil zeggen een gallium arsenide-laser van 5 milliwatt met een golflengte van 770-795 nanometer. Het lasergedeelte en de printer zijn zo ontworpen dat bij normaal gebruik, bij onderhoud of reparatie conform de voorschriften, nooit blootstelling mogelijk is aan laserstraling boven een niveau zoals voorgeschreven is voor klasse 1.

Lasermeddelelse

Printeren er godkendt som et Klasse I-laserprodukt, i overensstemmelse med kravene i IEC 825.

Klasse I-laserprodukter betragtes ikke som farlige. Printerens indeholder internt en Klasse IIIB (3b)-laser, der nominelt er en 5 milliwatt galliumarsenid laser, som arbejder på bølgelængdeområdet 770-795 nanometer. Lasersystemet og printerens er udformet således, at mennesker aldrig udsættes for en laserstråling over Klasse I-niveau ved normal drift, brugervedligeholdelse eller obligatoriske servicebetingelser.

Huomautus laserlættetesta

Tämä kirjoitin on Yhdysvalloissa luokan I (1) laserlaitteiden DHHS 21 CFR Subchapter J -määrityksen mukainen ja muualla luokan I laserlaitteiden IEC 825 -määrityksen mukainen.

Luokan I laserlaitteiden ei katsota olevan vaarallisia käyttäjälle. Kirjoittimessa on sisäinen luokan IIIB (3b) 5 milliwatin galliumarsenidilaser, joka toimii aaltoalueella 770 - 795 nanometriä. Laserjärjestelmä ja kirjoitin on suunniteltu siten, että käyttäjä ei altistu luokan I määräyksiä voimakkaammalle säteilylle kirjoittimen normaalin toiminnan, käyttäjän tekemien huoltotoimien tai muiden huoltotoimien yhteydessä.

VARO! Avattaessa ja suojalukitus ohitettaessa olet alttiina näkymättömälle lasersäteilylle. Älä katso säteeseen.

WARNING! Osynlig laserstråling när denna del är öppnad och spårren är urkopplad. Betrakta ej strålen.

Laser-notis

Denna skrivare är i USA certifierad att motsvara kraven i DHHS 21 CFR, underparagraf J för laserprodukter av Klass I (1). I andra länder uppfyller skrivaren kraven för laserprodukter av Klass I enligt kraven i IEC 825.

Laserprodukter i Klass I anses ej hälsovådliga. Skrivaren har en inbyggd laser av Klass IIIb (3b) som består av en laserenhet av gallium-arsenid på 5 milliwatt som arbetar i våglängdsområdet 770-795 nanometer. Lasersystemet och skrivaren är utformade så att det aldrig finns risk för att någon person utsätts för laserstrålning över Klass I-nivå vid normal användning, underhåll som utförs av användaren eller annan föreskriven serviceåtgärd.

Laser-melding

Skriveren er godkjent i USA etter kravene i DHHS 21 CFR, underkapittel J, for klasse I (1) laserprodukter, og er i andre land godkjent som et Klasse I-laserprodukt i samsvar med kravene i IEC 825.

Klasse I-laserprodukter er ikke å betrakte som farlige. Skriveren inneholder internt en klasse IIIb (3b)-laser, som består av en gallium-arsenlaserenhet som avgir stråling i bølglengdeområdet 770-795 nanometer. Lasersystemet og skriveren er utformet slik at personer aldri utsettes for laserstråling ut over klasse I-nivå under vanlig bruk, vedlikehold som utføres av brukeren, eller foreskrevne serviceoperasjoner.

Avís sobre el Làser

Segons ha estat certificat als Estats Units, aquesta impressora compleix els requisits de DHHS 21 CFR, apartat J, pels productes làser de classe I (1), i segons ha estat certificat en altres llocs, és un producte làser de classe I que compleix els requisits d'IEC 825.

Els productes làser de classe I no es consideren perillosos. Aquesta impressora conté un làser de classe IIIb (3b) d'arseniür de gal.li, nominalment de 5 mil.liuwats, i funciona a la regió de longitud d'ona de 770-795 nanòmetres. El sistema làser i la impressora han sigut concebuts de manera que mai hi hagi exposició a la radiació làser per sobre d'un nivell de classe I durant una operació normal, durant les tasques de manteniment d'usuari ni durant els serveis que satisfacin les condicions prescrites.

Japanese Laser Notice

レーザーに関するお知らせ

このプリンターは、米国ではDHHS 21 CFRサブチャプターJのクラスI (1)の基準を満たしたレーザー製品であることが証明されています。また米国以外ではIEC 825の基準を満たしたクラスIのレーザー製品であることが証明されています。

クラスIのレーザー製品には危険性はないと考えられています。このプリンターはクラスIII b (3 b)のレーザーを内蔵しています。このレーザーは、波長が770 ~ 795ナノメートルの範囲で、通常5ミリワットのガリウム砒化物を放射するレーザーです。このレーザーシステムとプリンターは、通常の操作、ユーザのメンテナンス、規定された修理においては、人体がクラスIのレベル以上のレーザー放射に晒されることのないよう設計されています。

Chinese Laser Notice

注意：

本打印机被美国认证合乎 DHHS 21 CFR Subchapter I 对分类 I (1) 激光产品的标准，而在其他地区则被认证合乎 IEC 825 的标准。

分类 I 激光产品一般认为不具危险性，本打印机内部含有分类 IIIb (3b) 的激光，在操作过程中会产生 5 毫瓦含镱及砷的微量激光，其波长范围在 770-795 nm 之间。本激光系统及打印机的设计，在一般操作、使用者维护或规定内的维修情况下，不会使人体接触分类 I 以上等级的辐射。

Korean Laser Notice

본프린터는 1등급 레이저 제품들에 대한 DHHS 21 CFR Subchapter 3의 규정을 준수하고 있음을 미국에서 인증받았으며, 그외의 나라에서도 IEC 825 규정을 준수하는 1등급 레이저 제품으로서 인증을 받았습니다.

1등급 레이저 제품들은 안전한 것으로 간주됩니다. 본 프린터는 5 밀리와트 갈륨 아르세나이드 레이저로서 770-795 나노미터의 파장대에서 활동하는 Class III (3b) 레이저를 내부에 갖고 있습니다. 본 레이저 시스템과 프린터는 정상 작동 중이나 유지 보수 중 또는 규정된 서비스 상태에서 상기의 Class I 수준의 레이저 방출에 사람이 절대 접근할 수 없도록 설계되어 있습니다.

Safety Information

- This product is designed, tested and approved to meet strict global safety standards with the use of specific Lexmark components. The safety features of some parts may not always be obvious. Lexmark is not responsible for the use of other replacement parts.
- The maintenance information for this product has been prepared for use by a professional service person and is not intended to be used by others.
- There may be an increased risk of electric shock and personal injury during disassembly and servicing of this product. Professional service personnel should understand this and take necessary precautions.

Consignes de Sécurité

- Ce produit a été conçu, testé et approuvé pour respecter les normes strictes de sécurité globale lors de l'utilisation de composants Lexmark spécifiques. Les caractéristiques de sécurité de certains éléments ne sont pas toujours évidentes. Lexmark ne peut être tenu responsable de l'utilisation d'autres pièces de rechange.
- Les consignes d'entretien et de réparation de ce produit s'adressent uniquement à un personnel de maintenance qualifié.
- Le démontage et l'entretien de ce produit pouvant présenter certains risques électriques, le personnel d'entretien qualifié devra prendre toutes les précautions nécessaires.

Norme di sicurezza

- Il prodotto è stato progettato, testato e approvato in conformità a severi standard di sicurezza e per l'utilizzo con componenti Lexmark specifici. Le caratteristiche di sicurezza di alcune parti non sempre sono di immediata comprensione. Lexmark non è responsabile per l'utilizzo di parti di ricambio di altri produttori.

- Le informazioni riguardanti la manutenzione di questo prodotto sono indirizzate soltanto al personale di assistenza autorizzato.
- Durante lo smontaggio e la manutenzione di questo prodotto, il rischio di subire scosse elettriche e danni alla persona è più elevato. Il personale di assistenza autorizzato, deve, quindi, adottare le precauzioni necessarie.

Sicherheitshinweise

- Dieses Produkt und die zugehörigen Komponenten wurden entworfen und getestet, um beim Einsatz die weltweit gültigen Sicherheitsanforderungen zu erfüllen. Die sicherheitsrelevanten Funktionen der Bauteile und Optionen sind nicht immer offensichtlich. Sofern Teile eingesetzt werden, die nicht von Lexmark sind, wird von Lexmark keinerlei Verantwortung oder Haftung für dieses Produkt übernommen.
- Die Wartungsinformationen für dieses Produkt sind ausschließlich für die Verwendung durch einen Wartungsfachmann bestimmt.
- Während des Auseinandernehmens und der Wartung des Geräts besteht ein zusätzliches Risiko eines elektrischen Schlags und körperlicher Verletzung. Das zuständige Fachpersonal sollte entsprechende Vorsichtsmaßnahmen treffen.

Pautas de Seguridad

- Este producto se ha diseñado, verificado y aprobado para cumplir los más estrictos estándares de seguridad global usando los componentes específicos de Lexmark. Puede que las características de seguridad de algunas piezas no sean siempre evidentes. Lexmark no se hace responsable del uso de otras piezas de recambio.
- La información sobre el mantenimiento de este producto está dirigida exclusivamente al personal cualificado de mantenimiento.

- Existe mayor riesgo de descarga eléctrica y de daños personales durante el desmontaje y la reparación de la máquina. El personal cualificado debe ser consciente de este peligro y tomar las precauciones necesarias.

Informações de Segurança

- Este produto foi concebido, testado e aprovado para satisfazer os padrões globais de segurança na utilização de componentes específicos da Lexmark. As funções de segurança de alguns dos componentes podem não ser sempre óbvias. A Lexmark não é responsável pela utilização de outros componentes de substituição.
- As informações de segurança relativas a este produto destinam-se a profissionais destes serviços e não devem ser utilizadas por outras pessoas.
- Risco de choques eléctricos e ferimentos graves durante a desmontagem e manutenção deste produto. Os profissionais destes serviços devem estar avisados deste facto e tomar os cuidados necessários.

Informació de Seguretat

- Aquest producte està dissenyat, comprovat i aprovat per tal d'acomplir les estrictes normes de seguretat globals amb la utilització de components específics de Lexmark. Les característiques de seguretat d'algunes peces pot ser que no sempre siguin òbvies. Lexmark no es responsabilitza de l'ús d'altres peces de recanvi.
- La informació pel manteniment d'aquest producte està orientada exclusivament a professionals i no està destinada a ningú que no ho sigui.
- El risc de xoc elèctric i de danys personals pot augmentar durant el procés de desmuntatge i de servei d'aquest producte. El personal professional ha d'estar-ne assabentat i prendre les mesures convenients.

安全资讯

- 本产品使用特有的 Lexmark 元件，并依照严格的世界安全标准来设计、测试及验证。有些零件的安全功能可能不明显。对于其他厂牌更换零件的使用，Lexmark 概不负责。
- 本产品的维护资讯仅供专业服务人员使用，而非针对一般使用者。
- 本产品在拆卸、维修的时候，遭受电击或人员受伤的危险性会增高，专业服务人员对这点必须有所了解，并采取必要的预防措施。

안전 사항

- 본 제품은 특정 Lexmark 구성 요소의 사용에 있어 엄격한 세계 안전 표준에 맞도록 설계, 테스트되었으며 승인받았습니다. 일부 부품의 안전성은 항상 보장되지 않습니다. Lexmark는 다른 교체 부품의 사용에 대한 책임을 지지 않습니다.
- 본 제품에 관한 유지 보수 설명서는 전문 서비스 기술자용으로 작성된 것이므로 비 전문가는 사용할 수 없습니다.
- 본 제품을 해체하거나 정비할 경우 전기적인 충격을 받거나 상처를 입을 위험이 커집니다. 전문 서비스 기술자는 이 사실을 숙지하고 필요한 예방 조치를 취하도록 하십시오.

1. General Information

Maintenance Approach

The diagnostic information in this manual leads you to the correct field replaceable unit (FRU) or part. Use the error code charts, symptom index, and service checks to determine the symptom and repair the failure.

After you complete the repair, perform tests as needed to verify the repair.

Tools

The removal and adjustment procedures described in this manual require the following tools and equipment:

- Magnetic tip Phillips screwdrivers, large and small
- Flat-blade screwdriver
- Analog volt ohmmeter (a digital volt ohmmeter may also be used)
- Needle nose pliers

When you make voltage readings, always use frame ground unless another ground is specified.

Abbreviations

ASIC	Application-Specific Integrated Circuit
CSU	Customer Setup
DRAM	Dynamic Random Access Memory
EEPROM	Electrically Erasable Programmable Read-Only Memory
EP	Electrophotographic Process
ESD	Electrostatic Discharge
FRU	Field Replaceable Unit
HVPS	High Voltage Power Supply
LAN	Local Area Network
LASER	Light Amplification by Stimulated Emission of Radiation
LCD	Liquid Crystal Display
LED	Light-Emitting Diode
LVPS	Low Voltage Power Supply
NVRAM	Nonvolatile Random Access Memory
OEM	Original Equipment Manufacturer
PICS	Problem Isolation Charts
PIXEL	Picture Element
POR	Power-On Reset
POST	Power-On Self Test
PQET	Print Quality Enhancement Technology
RIP	Raster Image Processor
ROS	Read-Only Storage
SRAM	Static Random Access Memory
UPR	Used Parts Replacement
VAC	Volts alternating current
VDC	Volts direct current

Mechanical Operation

This printer uses three motors to feed paper.

The pick-up motor drives the pick-up roller in the printer or in the multi-function feeder. The rotating direction of the motor determines which roller will be selected.

The paper feed motor drives the paper feed roller.

The main motor drives the fuser, the paper exit roller, and the redrive roller.

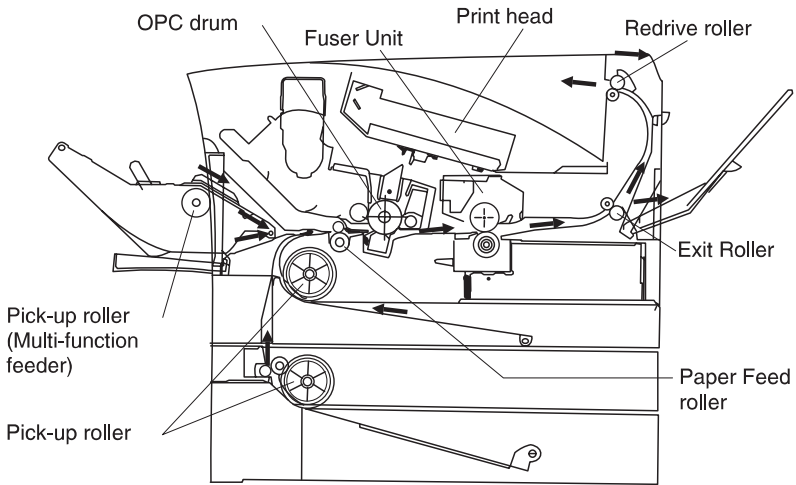

System Diagram

The central processing unit (CPU) in the main controller controls the entire printer and the data received from the interconnect.

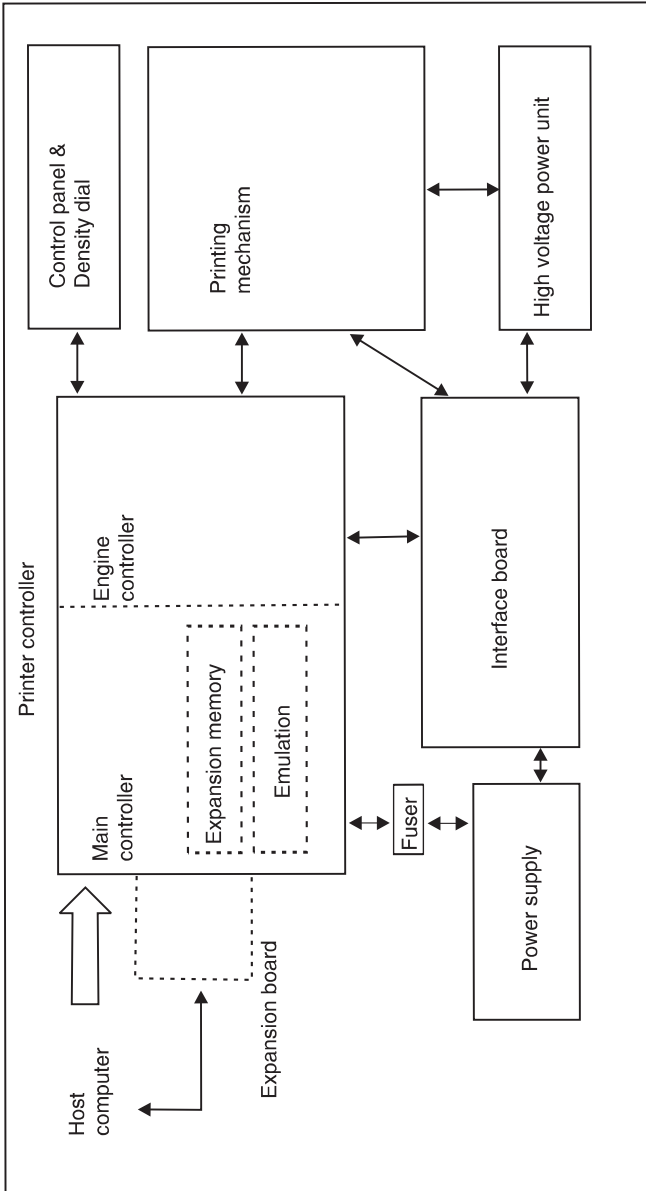

Printer Operation

1. When the printer receives a printing command, the main motor starts to rotate to initialize the print unit (including the photoconductive drum, developer, cleaning roller, and toner agitator) and to warm up the fuser. The motor in the printhead also starts to rotate to initialize the printhead.
2. The pick-up motor rotates counterclockwise to pick up paper from the paper tray. To print using the multi-function feeder, the host sends a paper select command. When receiving it, the pick-up motor rotates clockwise to drive the pick-up roller of the multi-function feeder. The paper feed motor starts to rotate to turn the paper feed roller.
3. The pick-up motor stops turning when the bottom edge of the paper exits the pick roller. The paper feed motor and the main motor continue to rotate the paper feeder roller, print unit, fuser, exit roller, and redrive roller until the paper passes through.
4. When the mechanism controller detects the bottom edge of the paper by the paper exit sensor, it stops both motors. The printer then waits for the next command.

Paper Feed Drive Mechanism

The main motor and the gear train are mounted on the metal frame.

The power of the pick-up motor gear is distributed to the pick-up roller of the paper tray or that of the multi-function feeder. Selection is determined by the rotating direction of the motor.

The power of the paper feed motor is distributed to the paperfeed roller.

Operation:

1. When the pick-up motor rotates counterclockwise, the power is transmitted to the pick-up roller of the paper tray through the center gear of the epicyclic gear train.
2. When the pick-up motor rotates clockwise, the power is transmitted to the pick-up roller of the multi-function feeder through the circumference gear of the epicyclic gear train.
3. When the paper feed motor rotates counterclockwise, the power

is transmitted to the paper feed roller.

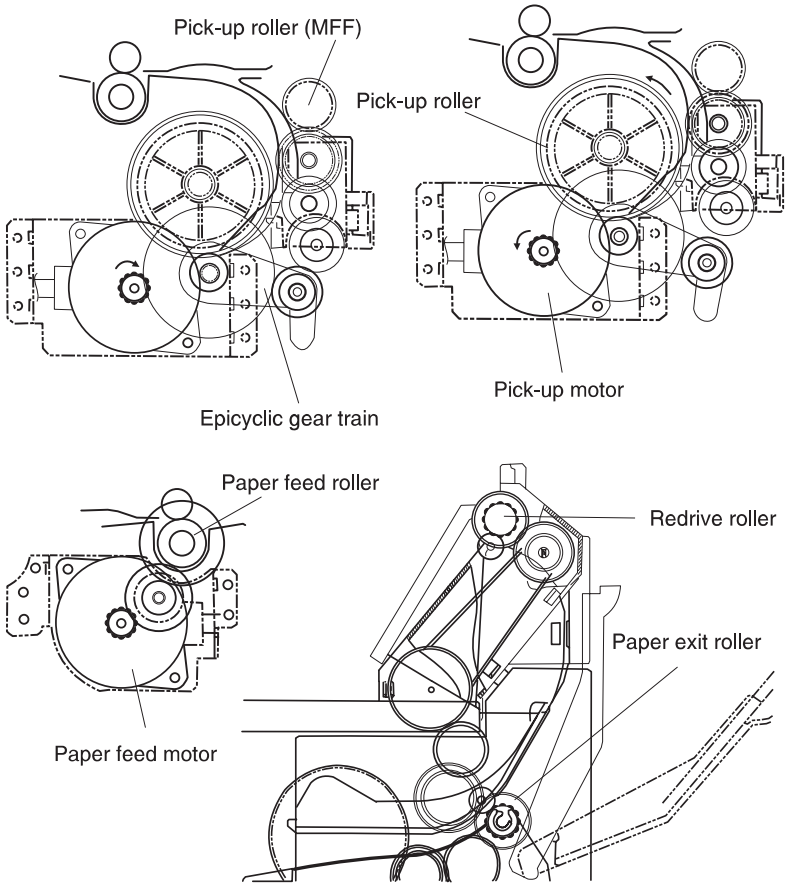

Process Drive Mechanism

The power of the main motor is distributed to the print unit, the fuser, and the paper eject roller. The power of the motor is transmitted to the print unit through gears A, B, C, and D, and to the hot roll of the fuser through gears A, B, C, E, and F.

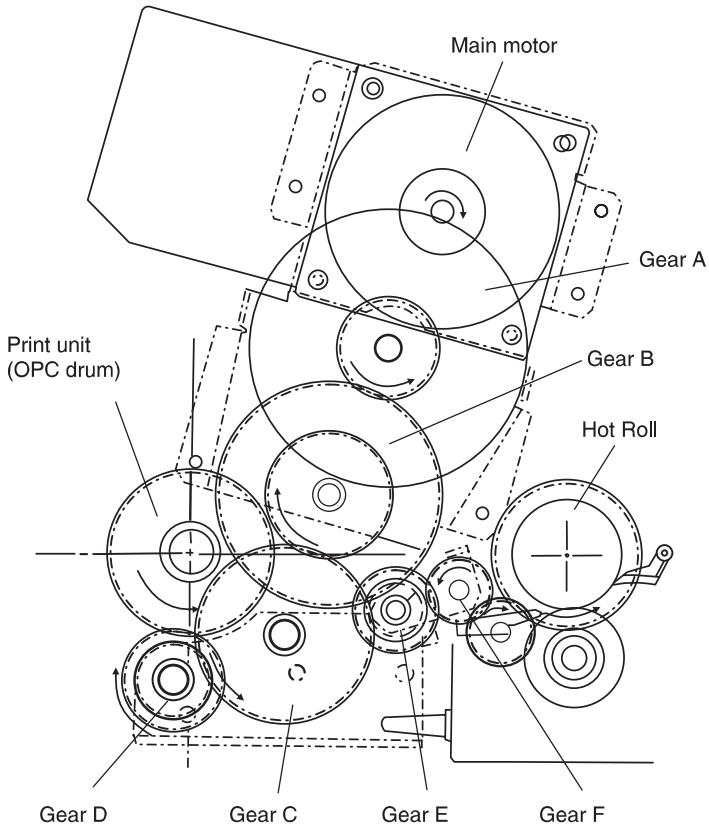

Print Unit

The print unit consists of a photoconductive drum (OPC drum), pre-charger assembly, developer assembly, recycle screw, and toner agitator.

Gear A receives power from the process drive assembly, transmitting the power to the photoconductive drum gear, the magnet roll (gear B), the toner agitator (gear C), the recycle screw, and gear D.

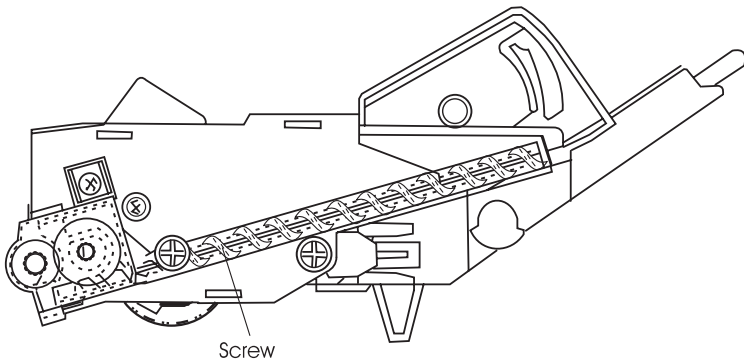
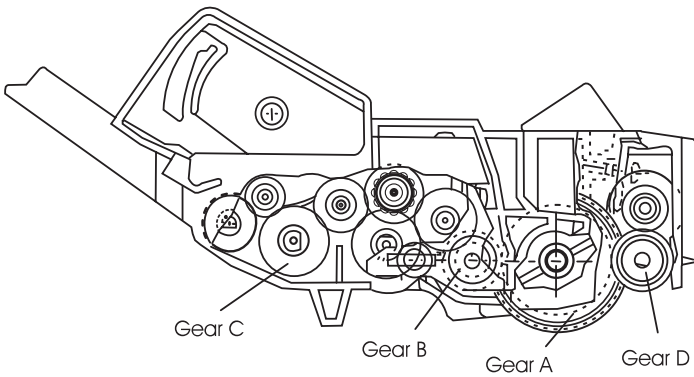

Fuser

The fuser consists of the hot roll assembly, and the backup roller. The hot roll has a halogen lamp, hot roll, temperature sensor, thermal fuse, and supporting parts. The back-up roller rotates with the hot roll.

Paper Ejection

Paper is ejected either through the rear stacker or the upper exit bin. When the stacker is folded down, paper exits the rear of the printer and rests on the rear stacker. When the stacker is in an upward position, it guides paper through the redrive roller which forces the paper

to the upper exit bin. Roller gears receive power from the hot roll gear.

2. Diagnostic Information

The diagnostic information in this chapter leads you to the failing part. Before you replace an entire assembly, determine if just the defective part is available in the parts catalog. Some diagnostic procedures indicate the parts catalog location of the part to be checked by including the assembly number and reference number in parenthesis. Some part numbers are also included. Use the error code tables, symptom table, service checks and the diagnostic aids chapter to determine the symptom and repair the failure. After you complete the repair, perform the appropriate tests to verify the repair.

If an error is displayed, locate it in the following Operator Error Message Table, or the Service Error Message Table and take the appropriate action.

If an error message appears while you are working on the machine, go to the error message table and take the indicated action.

Use the Locations chapter to find connector, board, and pin information. The sequence given in the service check is connector, board, and pin. The board uses only a letter for an identifier. For example, connector CN8A-3; CN8 = connector, A = board, -3 = the pin.

Start

Initial Check

Before you start troubleshooting, check the following:

Installation Environment

- The power supply line voltage is plus or minus 10% of the rated line voltage.
- The machine is securely installed on a level surface in a well-ventilated place.
- The room temperature is between 10 and 32°C (50 and 90°F) and the relative humidity between 20 and 80%.
- Avoid sites generating ammonia gas, high temperature or high humidity (near water faucets, kettles, humidifiers), cold spaces, near open flames, and dusty areas.
- Avoid sites exposed to direct sunlight.

Print Paper Checks

- Be sure the recommended paper for this printer is being used.
- Check the paper for dampness. Make a trial print with paper from a newly opened package, and check the results.

Service Error Code Table

Error Code	Action
900 RIP Software	Replace the controller board.
920 Fuser Error	Indicates the fuser is not operating at the correct temperature. Go to the "Fuser Service Check" on page 2-13.
935 Printhead Error	The mirror motor is not operating correctly. Go to the "Printhead Service Check" on page 2-26.
936 Transport Motor	Go to the "Main Motor Service Check" on page 2-20.
939 RIP to Engine Comm.	<p>The controller board and the engine board cannot communicate with each other. Be sure each board is installed correctly. If you don't find a problem, replace the controller board. If you still have a problem, replace the engine board.</p> <p>The controller software can also cause this error code. Contact your next level for software support.</p>
941 RIP Code CRC	Replace the controller board.
941 RIP Font CRC	Replace the controller board.
943 RIP Font Version	The RIP code and font ROM are incompatible
944 RIP Card Failure	The processor is failing. Replace the controller board.
945 RIP Card Failure	Indicates an ASIC failure. Replace the controller board.
946 RIP Card Failure	Indicates SRAM is failing. Replace the controller board.
947 Engine Card	Replace the engine board.
953 NVRAM Failure	Indicates the NVRAM chip on the engine board has failed. Replace the engine board.

Error Code	Action
954 NVRAM Failure	Indicates the NVRAM chip on the engine board has experienced a CRC failure. Replace the engine board.
960 RAM Memory Error	Replace the controller board.
961 RAM Memory Error	Indicates a problem with the expanded memory. Replace the SIMM. If you still have a problem, replace the controller board.
964-965 Emulation Error	<p>Indicates a failure with the Download Emulation programmed into the code overlay SIMM. The specific errors are:</p> <p>964 - Download Emulation CRC Failure. Checksum failure detected.</p> <p>965 - Download Emulation outdated. Go to "Disabling Download Emulations" on page 3-4.</p>
975-979 Network Card	<p>Indicates a failure with the network card. Replace the network card. The specific errors are:</p> <p>975 - Unrecognizable network card</p> <p>976 - Unrecoverable software error in network card communications.</p> <p>978 - Bad checksum while programming network card.</p>

User Error Messages

User Error Message	Explanation
200 Paper Jam Remove Cartridge	Paper is jammed at the printer Input Sensor. Open the printer's upper front door and remove the print cartridge to access the paper jam area.
201 Paper Jam Remove Cartridge	Paper is jammed between the printer's input and exit sensors. Open the printer's upper front door and remove the print cartridge to access the jam area.
202 Paper Jam Open Rear Door	Paper is jammed at the printer exit sensor. Open the printer rear door to access the jam area.
240 Paper Jam Check Tray 1 242 Paper Jam Check Tray 2	Paper has jammed as it exits tray 1 or tray 2. Try opening the tray. If the tray is difficult to remove, then you may have to remove the tray above or below to remove the jammed pages.
Insert Tray X	The printer is requesting the operator to insert tray X in order to continue printing the job. Insert tray X.
Change Tray X	The printer is requesting the operator to insert tray X with a specific type/size of paper. Insert the correct tray with the paper type/size specified. If the correct tray is inserted and the error message remains, press Go to clear the message.
Load Tray X	The printer senses that tray X is empty. Load the requested type/size of paper and insert tray X.
Remove Paper Standard Bin	The printer senses that the standard output bin is full.
Close Upper Door	The upper front door is open. Close the door to continue printing.
Insert Print Unit or Toner	The printer senses that either the print unit is not installed or is installed without any toner in the toner reservoir.

User Error Message	Explanation
34 Short Paper	The printer determines the paper length is too short to print the formatted data. This occurs when the printer does not know the actual paper size loaded in the tray. For auto-size sensing trays, this error occurs if the paper stop is in the incorrect position. Make sure the Paper Size setting is correct for the size paper that is being used.
35 Res Save Off Deficient Memory	The printer lacks sufficient memory to enable Resource Save. This message usually indicates the user has allocated too much for one or more of the printer's link buffers; however, modification of other printer settings which affect the amount of available memory may also create this condition. Have the user either install additional memory or set each link buffer back to the Auto value.
36 Resolution Reduced	The resolution of the page has been reduced from 600 dpi to 300 dpi to prevent a Memory Full error. This message can only occur if the Resolution Reduction setting is turned on. Note: 1200 dpi pages are not resolution reduced. If a 1200 dpi job runs out of memory, a Memory Full error is displayed.
37 Insufficient Collation Memory	This message is displayed when the printer memory used to store pages is too full to collate the print job.
38 Memory Full	This message is displayed when the printer memory used to store pages is full.
39 Complex Page	This message is displayed when the page is too complex to print.
51 Defective Flash	This message is displayed when the printer detects a defective flash. This error may occur at power on, or during flash format and write operations. Press Go to clear the message. The flash is marked as bad and normal operation continues. Flash operations are not allowed until the problem is resolved.
52 Flash Full	This message is displayed when there is not enough free space in the flash memory to hold the resources that have been requested to be written to flash.

User Error Message	Explanation
53 Unformatted Flash	This message is displayed when the printer detects an unformatted flash at power on. Press Go to clear the message. The flash is marked as bad and normal operation continues. Flash operations are not allowed until the flash is formatted.
54 Standard Serial Error	This error is displayed when a serial error (framing or parity) is detected on the standard serial port. This usually indicates the serial port is not set up correctly.
54 Serial Option X Error	This error is displayed when a serial error (framing or parity) is detected on the optional serial port. This usually indicates the optional serial port is not set up correctly.
56 Standard Serial Disabled	This error is displayed when data is sent to the printer across the standard serial port, but the port has been disabled.
56 Parallel Port Disabled	This error is displayed when data is sent to the printer across the parallel port, but the parallel port has been disabled. Once this message is displayed, reporting of further errors is suppressed until the menus are entered, or the printer is reset.
61 Defective Disk	This error code is displayed when the printer detects a defective disk. This error may occur at power on or during disk format and write operations. The following actions may be taken while this message is displayed: Press Go to clear the message. The disk is marked defective and normal printer operations continue. Disk operations are not allowed with a defective disk. The Format Disk menu is not shown.
62 Disk Full	This error code is displayed when there is not enough free space on the disk to hold the resources that have been requested to be written to the disk. This message displays for both resource and PostScript Disk operators when the disk is full.

User Error Message	Explanation
63 Unformatted Disk	This error code displays when the printer detects an unformatted disk at power on. Press Go to clear the message. The disk is marked as bad and normal operation continues. Disk operations are not allowed until the disk is formatted.
88 Toner Low	This error displays when toner low occurs and the toner low alarm is activated. Press Go to clear this message.
88 Toner Out	This error displays when toner is depleted. When the toner bottle is refilled, printing resumes automatically.

Symptom Table

Symptom	Action
Engine Fan Failure	Go to the “Engine Fan Service Check” on page 2-11.
Process Fan Failure	Go to the “Process Fan Service Check” on page 2-27.
Operator panel is unresponsive or doesn't display any or all characters.	Go to the “Operator Panel Display Service Check” on page 2-22.
Paper Feed or Paper Jam Problems	Go to the “Paper Feed Service Check” on page 2-24.
Fuser Problems	Go to the “Fuser Service Check” on page 2-13.
All Black Page	Go to “Image Quality Service Check” on page 2-13.
Blank Page	Go to “Image Quality Service Check” on page 2-13.
Light Print	Go to “Image Quality Service Check” on page 2-13.
Residual Image	Go to “Image Quality Service Check” on page 2-13.

Symptom	Action
Image Banding	Go to “Image Quality Service Check” on page 2-13.
Background	Go to “Image Quality Service Check” on page 2-13.
Toner on Backside of Paper	Go to “Image Quality Service Check” on page 2-13.
Random Vertical Streaks	Go to “Image Quality Service Check” on page 2-13.
Blurred Print	Go to “Image Quality Service Check” on page 2-13.
Evenly Spaced Horizontal Marks or Lines	Go to “Image Quality Service Check” on page 2-13.
Malfunctions with Options	Go to the “Options Service Check” on page 2-23.
Standard Output Bin Problems	Go to the “Standard Bin Full Sensor Service Check” on page 2-27.

Service Checks

Cover Open Switch Service Check

Run the “Base Sensor Test” on page 3-11. Check the cover open switch for proper operation. The display changes from open to closed as the upper door is opened and closed.

	FRU	Action
1	Cover Open Switch	Be sure the cover open switch is properly installed in the left print unit guide. If you still have a problem, remove the interconnect board and check the connection of the cover open switch cable (CNCOV2). If it is correct, test the continuity of the switch. The switch circuit is normally closed. When the switch is pressed, the circuit opens.

2	<ul style="list-style-type: none"> • Interconnect Board • Engine Board 	<p>Replace these FRUs in the following order:</p> <ol style="list-style-type: none"> 1. Interconnect Board 2. Engine Board
---	--	--

Dead Machine Service Check

	FRU	Action
1	Line Voltage	Check the ac voltage. If the line voltage is incorrect, inform the customer.
2	AC Line Cord	Inspect the cord for damage. If it is OK, check the continuity.
3	Power Supply Fuse	<p>Remove the power supply. Check the continuity of the fuse. Install the power supply.</p> <p>There is no check you can make of the power supply while it is removed from the machine.</p> <p>Check the exit sensor flag for correct operation. The printer will not turn on unless the flag is passing through the sensor.</p> <p>Check the connector pins on the interconnect board where the power supply plugs in. These pins may be bent.</p>
4	Controller Board	<p>Remove the controller board. Turn the printer on. If the Ready LED comes on, turn off the printer. Remove any options plugged into the controller board and re-install the controller board. Turn the printer on. If the machine powers up normally, one of the options is defective. Re-install each option one at a time to determine which one is defective. If the machine did not power up normally when you re-installed the controller board, replace the controller board.</p>

5	<ul style="list-style-type: none"> • LVPS • Engine Board • Interconnect Board 	<p>Check engine board connector CNMC for the following voltages:</p> <p>CNMC-A1 = +5 V dc CNMC-B16 = +5 V dc</p> <p>If the voltages are correct, check the operator panel cable condition and connection. If the voltages are incorrect, disconnect all cables from the engine board but leave the engine board connected to the interconnect board. Measure the following voltages again:</p> <p>CNMC-A1 = +5 V dc CNMC-B16 = +5 V dc</p> <p>If the voltages are now correct, reconnect each cable until the voltage is incorrect. Replace the FRU causing the change in voltage.</p> <p>If the voltage is still incorrect, replace the following FRUs in the order shown:</p> <ol style="list-style-type: none"> 1. LVPS 2. Interconnect board 3. HVPS 4. Engine board
---	--	--

Engine Fan Service Check

	FRU	Action
1	Engine Fan	<p>Be sure the engine fan turns on during POST. If it does not, be sure the fan is connected properly.</p> <p>Check the voltage on the engine board between CNF2-1 and CNF2-2. If the voltage is +24 V dc, replace the engine fan. If the voltage is incorrect, replace the engine board.</p>

Erase LED Service Check

	FRU	Action
1	<ul style="list-style-type: none"> • Erase LED Assembly • Engine Board 	<p>Be sure the erase LED cable is correctly connected to the CNERS connector on the engine board.</p> <p>Disconnect the LED cable and check CNERS-1 on the engine board for +24 V dc. If the voltage is incorrect, replace the engine board. If the voltage is correct, replace the erase LED.</p>

Exit Sensor Service Check

Error Code 202 Paper Jam Open Rear Door may display if the exit sensor flag is stuck down or defective.

The printer will not power up if the exit sensor flag is not in the sensor.

	FRU	Action
1	Exit Sensor Flag	Check the exit sensor flag for correct position and operation. The flag should protrude upward into the paper path and swing to a downward position as the paper passes over it. The opposite end of the flag should rest in the exit sensor while the flag is in the upward position and move out of the sensor as the paper pushes the flag. Replace the flag if necessary.
2	Power Supply Board	The exit sensor is mounted to the power supply board. If the sensor flag is operating correctly, replace the power supply board.

Fuser Service Check

	FRU	Action
1	920 Fuser Error, Lamp does not come on	<p>Check the connection of the lamp cable at the LVPS and at the thermal fuse. Be sure the lamp is not burned out or broken.</p> <p>Check the thermal fuse for conductivity. If the thermal fuse conducts no current, replace the fuser.</p> <p>If the connections are correct the lamp is good and the thermal fuse is good. Replace the following FRUs in the order shown:</p> <ol style="list-style-type: none">1. LVPS2. Engine Board
2	920 Fuser Error, Lamp does turn on	<p>Check the fuser for signs of excessive toner buildup on the hot roll, backup roll, and thermistor. Be sure the Thermistor is not bent, loose, or in the wrong position. The thermistor should make contact with the hot roll. Be sure the resistance of the thermistor is between the range of 50 Ohms (hot) and 60k Ohms (cold). If the resistance is out of this range, replace the fuser. If you still have the problem replace the following FRUs in the order shown:</p> <ol style="list-style-type: none">1. LVPS2. Engine Board

Image Quality Service Check

Before you troubleshoot a print quality problem, do the following:

- Install another print unit if available
- Use Tray 1 to test for quality of the base printer

Select the following settings. Be sure to note the original settings so you can return the printer to the original setup.

- Print Resolution: Set to 300 dpi (print quality problems should be checked at different resolution settings)
- Toner Saver: Set to off.
- PQET: Set to off.
- Print Darkness: Adjust knob to the middle setting.

An incorrect printer driver for the installed software can cause problems. Incorrect characters could print and the copy may not fit the page properly.

Measure all voltages from the connector to printer ground.

Be sure to turn the printer off before you make any checks on the transfer corona.

Locate your symptom below, note the possible causes, and take the appropriate action. Be sure all associated connectors are plugged in correctly.

Print Quality - All Black Page

	FRU	Action
1	Print Unit	Check the precharger wire on the print unit for dirt or damage. Clean the wire with the cleaning tool provided with the printer. If the wire has come loose from the print unit, the customer must replace the print unit.
2	HVPS	Check the HVPS contacts on the HVPS board and the mating contact springs on the left side of the printer for pitting or incorrect alignment. Cables from the pick roller motor and cover open switch can get in the way of the contacts.
3	<ul style="list-style-type: none">• Interconnect Board• Engine Board	Be sure the HVPS connects to the interconnect board correctly. Be sure the interconnect board connects to the engine board correctly. If all the connections are correct, replace the following FRUs in the order shown: <ol style="list-style-type: none">1. HVPS2. Interconnect Board3. Engine Board

Print Quality - Blank Page

	FRU	Action
1	Printhead Cable	Generally a 935 Printhead Error is posted if the printhead assembly fails. Check the connection of the printhead.
2	Transfer Corona	Check the transfer corona for correct installation or signs of damage. Clean the transfer wire with the cleaning tool provided with the printer. Check the contact spring that connects to the transfer corona for damage, pitting, or debris. Replace the transfer or center paper feed frame, which contains the spring, if necessary. Also see the “Transfer Corona Service Check” on page 2-29.
3	Print Unit	Check the print unit for any signs of damage, especially the PC drum and contacts. Also check the precharger wire for damage. Clean the wire with the cleaning tool provided with the printer.
4	<ul style="list-style-type: none"> • Contact Springs • HVPS 	Check the HVPS contacts on the HVPS board and the mating contact springs on the left side of the printer for pitting or incorrect alignment. Cables from the pick roller and cover open switch could also be in the way of the contacts.
5	<ul style="list-style-type: none"> • Engine Board • HVPS • Interconnect Board 	<p>Check the voltages on the engine board at the following locations;</p> <p>Printer Idle: CNMC-B10 = +24 V dc CNMC-B11 = +17 V dc CNMC-A11 = +20.5 V dc CNMC-B12 = +0.1 V dc</p> <p>Printer Printing: CNMC-B10 = +0.1 V dc CNMC-B11 = +0.1 V dc CNMC-A11 = +0.1 V dc CNMC-B12 = momentarily jumps up to 5 - 15 V dc.</p> <p>If these voltages are not correct, replace the engine board. If they are correct, replace the following FRUs in the order shown:</p> <ol style="list-style-type: none"> 1. HVPS 2. Interconnect Board

Print Quality - Light Print

	FRU	Action
1	Transfer Corona	Check the transfer corona for dirt or damage. Check the contact and contact spring for pitting or contamination. Clean or replace as necessary. Also see the “Transfer Corona Service Check” on page 2-29 .
2	HVPS	<p>Check the contact spring and HVPS contact for pitting, cable interference, or incorrect installation. Clean if necessary.</p> <p>Check the voltages on the engine board at the following locations;</p> <p>Printer Idle: CNMC-B10 = +24 V dc CNMC-B11 = +17 V dc CNMC-A11 = +20.5 V dc CNMC-B12 = +0.1 V dc</p> <p>Printer Printing: CNMC-B10 = +0.1 V dc CNMC-B11 = +0.1 V dc CNMC-A11 = +0.1 V dc CNMC-B12 = momentarily jumps up to 5 - 15 V dc.</p> <p>If these voltages are not correct, replace the engine board. If they are correct, replace the following FRUs in the order shown:</p> <ol style="list-style-type: none">1. Transfer Corona2. HVPS3. Interconnect Board

Print Quality - Residual Image

Install a new print unit if one is available, before you begin this check. Residual image can be caused by the photoconductor, cleaning mechanism, and other parts inside the print unit.

	FRU	Action
1	Erase LED Assembly	Check the erase LED for signs of paper dust, toner build-up or other contamination. Clean with a soft cloth or replace the erase LED assembly. When the erase LEDs work properly, each LED turns bright red. This is visible with the print unit removed, by opening the upper door during the warming engine step in the POST procedure. If the erase LEDs do not come on, check the voltage at CNERS-1 on the engine board. It should measure +24 V dc. If it is incorrect, replace the engine board. If it is correct, replace the erase LED assembly.
2	Fuser	Check the fuser for signs of toner buildup on the hot roll. Toner buildup could cause the hot roll to pick up toner and deposit it down the page. If buildup is present, replace the fuser.

Print Quality - Banding

Banding appears as light or dark horizontal lines on a uniformly gray page, or on a page with a large area of graphics. Banding is primarily due to a variation in the speed of the paper as it feeds through the printer, especially in the developer and transfer process. Inspect the paper feed components, especially the drive gears, for signs of wear, dirt, binds, or damage.

Print Quality - Background

Some background problems can be caused by an incorrect paper setting. Be sure the correct paper type setting is selected for the paper being used. Background can also be caused by an incorrect setting on the print darkness control. The customer may try to improve the print quality by adjusting the print darkness dial.

Light that enters the machine while some covers are removed may cause background.

	FRU	Action
1	Erase LED	See the "Erase LED Service Check" on page 2-11.
2	Printhead	The printhead is a sealed unit and cannot be cleaned. Try a replacement printhead only if all other attempts to correct a background problem fail.
3	Transfer Corona	Check the transfer corona assembly for signs of toner buildup and contamination. Use the cleaning tool provided with the printer to clean the wire. Check the wire for damage. The wire should be positioned across the corona housing. Replace the corona if the wire is broken, stretched, or loose. See also the "Transfer Corona Service Check" on page 2-29.
4	<ul style="list-style-type: none"> • Contact Springs • Engine Board • HVPS • Interconnect Board 	<p>Check the contact spring and HVPS contact for pitting, cable interference, or incorrect installation. Clean if necessary.</p> <p>Check the voltages on the engine board at the following locations;</p> <p>Printer Idle: CNMC-B10 = +24 V dc CNMC-B11 = +17 V dc CNMC-A11 = +20.5 V dc CNMC-B12 = +0.1 V dc</p> <p>Printer Printing: CNMC-B10 = +0.1 V dc CNMC-B11 = +0.1 V dc CNMC-A11 = +0.1 V dc CNMC-B12 = momentarily jumps up to 5 - 15 V dc.</p> <p>If these voltages are not correct, replace the engine board. If they are correct, replace the following FRUs in the order shown:</p> <ol style="list-style-type: none"> 1. HVPS 2. Interconnect Board

Print Quality - Toner on the Back Side of a Printed Page

	FRU	Action
1	Fuser	Toner is being carried out on the back side of the media. The problem is generally caused by a toner buildup on the fuser hot roll or backup roll. Check these rolls for any noticeable buildup of toner. Replace the fuser if necessary.
2	Transfer Corona	Check the transfer corona for toner buildup or loose toner. Toner in this area can usually be cleaned from the printer. Replace the transfer corona if it is excessively contaminated or if you cannot clean it. See also the "Transfer Corona Service Check" on page 2-29 .
3	Print Unit	Check the precharger wire on the print unit for dirt or contamination. Clean the print unit with the tool provided with the printer. Check the PC drum on the print unit for loose debris or foreign material. Clean the debris from the print unit but do not touch the PC drum surface. If you still have the problem, inform the customer the print unit must be replaced.

Print Quality - Blurred Print

Blurred print is usually caused by a problem in the feed roller, main motor gear box assembly, or other gears transferring power to the feed rollers. Check the gears for contamination of binds. Also be sure the paper is feeding correctly from all available input trays.

Print Quality - Evenly Spaced Horizontal Lines or Marks

Distance Between Lines or Marks	Cause and Action
93mm (3.6 inches)	This can be caused by the PC drum or the gear driving the PC drum on the print unit. Inform the customer the print unit needs to be replaced.
55mm (2.2 inches)	This can be caused by the main motor gear box assembly. Replace the gear box assembly.

Distance Between Lines or Marks	Cause and Action
49mm (1.9 inches)	This can be caused by the feed roller or gear that turns the feed roller. Inspect for damage and replace as necessary.
24mm (0.9 inch)	This can be caused by a gear in the print unit. Inform the customer the print unit needs to be replaced.
68mm (2.7 inches)	This can be caused by a gear in the fuser. Check the fuser gears for contamination or damage. Replace the fuser if necessary.

Main Motor Service Check

	FRU	Action
1	<ul style="list-style-type: none"> • Engine Board • Main Motor 	<p>Be sure the main motor cable is connected properly. Replace it if it is damaged.</p> <p>Disconnect the main motor cable and check the voltage on the following connectors on the engine board:</p> <p>CNMM-1 = +24 V dc CNMM-2 = +24 V dc</p> <p>If the voltages are correct, replace the main motor. If the voltages are incorrect, replace the engine board.</p>

Input Sensor Service Check

Error Code 200 Paper Jam Remove Print Unit may display if the input sensor flag is stuck down or defective.

Error Code 240 Paper Jam Tray or Feeder may display if the input sensor flag is broken or stuck in the upward position.

Paper jam error codes may be caused by a faulty or worn pick roller.

Before you continue, run the **“Input Tray Feed Test”** on page 3-10. A defective input sensor or circuit will cause the first copy to exit only partially through the fuser assembly.

	FRU	Action
1	Input Sensor Flag	Check the input sensor flag for proper position and operation. The flag is visible if you open the manual feed tray. The position of the flag should be in the paper path such that when printing, the paper pushes the flag down. Replace the flag if it is damaged.
2	Input Sensor	The input sensor is mounted on the interconnect board. The sensor flag swings through the sensor as the paper makes contact with the flag. If it is operating correctly, replace the following FRUs in the order shown: 1. Interconnect Board 2. Engine Board

Operator Panel Buttons Service Check

Before you continue, perform the **“Button Test”** on page 3-6.

	FRU	Action
1	Operator Panel	If any of the buttons failed the Button Test, replace the operator panel.
2	Engine Board (No buttons work.)	Disconnect the operator panel cable from the engine board. Turn the power on. Check the voltage at CNOP-1. It should measure approximately +5 V dc. If it is incorrect, replace the engine board. If it is correct, check the continuity of the operator panel cable. If the continuity is not correct, replace the cable. If the cable is good, replace the operator panel.

Operator Panel Display Service Check

Before you continue, perform the **“LCD Test”** on page 3-5.

	FRU	Action
1	Operator Panel	If the operator panel failed the LCD Test, replace it.
2	Operator Panel Cable	Be sure the cable is properly connected to the engine board (CNOP) and the operator panel. Check the condition and continuity of the cable.
3	Engine board	Disconnect the operator panel cable. Check the voltage at CNOP-1 on the engine board. It should measure +5 VB dc. If it is correct, replace the operator panel. If the voltage is incorrect, replace the engine board.

Options Service Check

Flash Memory Option

Run a copy of the test page to see if the option you are checking is listed. The printer does not recognize the option being installed if the option is not listed. Be sure the memory SIMM is installed correctly and is not broken or damaged. Run the **“Flash Test” on page 3-3**. If the test fails, replace the flash SIMM. If the problem continues, replace the controller board.

DRAM Memory Option

Run a copy of the test page to see if the option you are checking is listed. The printer does not recognize the option being installed if the option is not listed. Be sure the DRAM SIMM is installed correctly and is not broken or damaged. Run the **“DRAM Memory Test” on page 3-6**. If the test fails, replace the DRAM SIMM. If the problem continues, replace the controller board.

Hard Disk Option

Be sure the fixed disk and the fixed disk board are correctly installed. Run the **“Quick Disk Test” on page 3-2**.

The Quick Disk Test is a non-destructive test and indicates Pass or Fail. If the test fails, replace the hard disk. If the problem remains, replace the hard disk board.

The **“Disk Test/Clean” on page 3-3**, helps restore the disk if the disk contains bad data and is unusable. This test is divided into a cleaning and verifying, or testing section. This can be a very lengthy test depending on the disk size, and leaves the hard disk unformatted. The servicer or user must reformat the disk using the Format Disk menu operation. This is a destructive type test and should not be performed on a known good disk. All the data on the disk is destroyed.

Network Card Option

Error code 975 indicates the printer cannot recognize the network card. Error code 976 indicates an unrecoverable software error in the network card.

Verify the network card is installed correctly and is properly grounded. If you find no problem, replace the network card. If the problem remains, replace the controller board.

Paper Feed Service Check

Be sure the size indicator on the paper tray is in the correct position before performing the service check.

If you have a 936 Transport Motor Error go to the [“Main Motor Service Check” on page 2-20](#).

Locate your symptom from the following information and perform the check.

Pick Roller Fails to Pick Paper

	FRU	Action
1	Pick Roller	Check the pick roller for wear, scratches, or rough spots. Replace if necessary.
2	Pick Motor	Watch the motion of the pick motor as you try to print a test page. If the motor does not turn, check the print motor connector at the interconnect board. If it is correct, disconnect the motor cable and check the impedance of the motor windings across the following motor connector locations: CNRM-1 to CNRM-2 = approximately 30 Ohms CNRM-3 to CNRM-4 = approximately 30 Ohms If incorrect, replace the pick motor. If correct, replace the following FRUs in the order shown: 1. Interconnect Board 2. Engine Board

3	Pick Roller Gear	<p>If the motor is operating correctly, check the pick roller gear train. The pick roller gear contains a clutch that allows rotation in only one direction. If it is installed backwards, the pick roller cannot pick the paper. If the pick roller gear is properly installed but not working correctly, replace the gear.</p> <p>To determine if the roller gear is positioned correctly, remove the paper tray and roll the pick roller by hand. If you slide your hand toward the front of the printer, the roller should rotate freely with little resistance. If you slide your hand toward the rear of the printer, the pick roller should resist rolling and cause the pick motor to turn.</p>
---	------------------	---

Pick Roller Feeds Paper but Stops or Jams at Input Feed Roll

	FRU	Action
1	Paper Path	Open the upper door, remove the print unit, and check for loose debris in the paper path. Clean as necessary.
2	Input Sensor	Go to the “Input Sensor Service Check” on page 2-21 .
3	Paper Feed Roll	Check the paper feed roll for wear and replace as necessary.
4	Paper Feed Motor	<p>Be sure the paper feed motor is connected properly. Be sure the motor turns when you print a test page.</p> <p>If the motor does not turn, disconnect the motor cable and check the impedance of the motor windings across the following motor connector locations:</p> <p>CNRM-1 to CNRM-2 = approximately 30 Ohms CNRM-3 to CNRM-4 = approximately 30 Ohms If incorrect, replace the paper feed motor</p>

Failures Occur at or Near the Bottom of the Stack of Paper

The paper tray lift plate may not be lifting the paper with enough force for the pick roller to move the paper. Check the paper tray lift plate spring for proper operation. Also check the pick roller for wear, scratches, or rough spots.

Double Feeding

Paper is usually the primary cause of double feeding. Flex the paper before you place it in the tray. Edge welded paper is the most common cause of double feeding. Loading the paper in the tray in different locations and directions, and using rough paper and short grain paper can also cause double feeding.

	FRU	Action
1	Paper Tray Separator Pad	Check the separator pad in the paper tray. A worn or incorrectly installed separator may cause mis-feeding.

Parallel Port Service Check

Run the **“Parallel Wrap Test”** on page 3-7. Use wrap plug P/N 1319128. This test helps isolate the printer from the parallel cable and host. The test provides failure information on the display for approximately 3 seconds. If the test indicates a problem, replace the controller board.

Printhead Service Check

	FRU	Action
1	Printhead Cable	Check for wear on the cable. Be sure the cable is properly connected. Check the continuity of the cable.

	FRU	Action
2	Engine Board	<p>Disconnect the printhead cable and check the voltage on the engine board at the following locations:</p> <p>OPT-1 = +24 V dc OPT-2 = +24 V dc OPT-9 = Ground OPT-13 = Ground OPT-16 = +5 V dc OPT-19 = +5 V dc OPT-20 = Ground</p>

Process Fan Service Check

	FRU	Action
1	Process Fan	<p>Be sure the process fan turns on during POST. If it does not, be sure the fan is connected properly.</p> <p>Check the voltage on the engine board between CNF1-1 and CNF1-2. If the voltage is +24 V dc, replace the process fan. If the voltage is incorrect, replace the engine board.</p>

Serial Port Service Check

Run the **“Serial Wrap Test”** on page 3-8. Use wrap plug P/N 1319128. This test helps isolate the printer from the serial cable and host. The test provides failure information on the display for approximately 3 seconds. If the test indicates a problem, replace the following FRUs in the order shown:

1. Tri-Port Card or Serial Adapter
2. Controller board

Standard Bin Full Sensor Service Check

Enter the diagnostic mode and test the standard bin full sensor with the **“Base Sensor Test”** on page 3-11. Use the following checks to further isolate the problem.

“Remove Paper Standard Bin” message never appears:

	FRU	Action
1	<ul style="list-style-type: none">• Standard Bin Full Sensor• Sensor Cable• Engine Board	<p>Check the flag for damage or improper operation. If incorrect, replace the sensor.</p> <p>Disconnect the sensor cable from the engine board and check the cable for continuity.</p> <p>Check the voltage on the engine board at CNSF-1 It should be +5 V dc. If it is incorrect, replace the engine board. If it is correct, replace the sensor.</p>

“Remove Paper Standard Bin” message always appears when attempting printing:

	FRU	Action
1	<ul style="list-style-type: none">• Standard Bin Full Sensor• Sensor Cable• Engine Board	<p>Check the flag for damage or improper operation. If incorrect, replace the sensor.</p> <p>Disconnect the sensor cable from the sensor and print a test page. If the “Remove Paper Standard Bin” message does not appear and the test page prints successfully, replace the sensor.</p> <p>Disconnect the sensor cable from the engine board. Attempt another test page. If successful, replace the sensor cable.</p> <p>If you still have a problem, replace the engine board.engine board and check the cable for continuity.</p> <p>Check the voltage on the engine board at CNSF-1 It should be +5 V dc. If it is incorrect, replace the engine board. If it is correct, replace the sensor.</p>

Toner Sensor Service Check

An “Insert Print Unit or Toner” or “88 Toner Empty” message may appear if the toner sensor cable is not seated correctly or if the cable is defective.

	FRU	Action
1	Toner Sensor	<p>Be sure the toner sensor cable is seated properly. Check the voltage at CNTN-1 on the engine board. If it is not +5 V dc, replace the engine board. If the voltage is correct, check the voltage at CNTN-3. If it is not ground, replace the engine board.</p> <p>If the voltages are correct, replace the toner sensor.</p>

Transfer Corona Service Check

Be sure you turn the printer off before you make any checks on the transfer corona.

	FRU	Action
1	Transfer Corona	<p>Check the transfer corona assembly for signs of toner buildup and contamination. Use the cleaning tool provided with the printer to clean the wire. Check the wire for damage. The wire should be positioned across the corona housing. Replace the corona if the wire is broken, stretched, or loose.</p>
2	HVPS	<p>Check the HVPS contacts for pitting or cables interfering with the contacts. If correct and replacing the transfer corona does not improve the problem, replace the FRUs in the following order:</p> <ol style="list-style-type: none">1. HVPS2. Interconnect Board3. Engine Board

3. Diagnostic Aids

This chapter explains the tests and procedures to identify printer failures and verify repairs have corrected the problem.

To run the printer diagnostic tests described in this chapter, you must put the printer in Diagnostic Mode.

Diagnostic Mode

To enter the Diagnostic Mode:

1. Turn the printer off.
2. Press and hold the Go and Return buttons.
3. Turn the printer on.
4. Release the buttons when "Performing Self Test" displays on the operator panel.

The tests display on the operator panel in the order shown:

- Device Tests
- Print Registration
- Print Tests
- Hardware Tests
- Input Tray Tests
- Base Sensor Tests
- Printer Setup
- Error Log

Exiting the Diagnostic Mode

Select Exit Diagnostics to exit the Diagnostic Mode and return to normal mode.

Power-On Self Test (POST)

When you turn the machine on the following POST sequence takes place:

1. The Power LED turns on.
2. Diamonds scroll across the display, then clear.
3. "Performing Self Test" appears on the display.
4. The printhead mirror motor turns on.
5. "Warming Engine" appears on the display and the Busy LED starts flashing.
6. The fuser lamp turns on to warm the engine. The fuser takes longer to warm up from a cold start than a warm start.
7. The process and engine fans turn on.
8. The main motor turns on which turns the fuser hot roll, backup roll, exit rollers, and developer gears in the print unit.
9. Once the engine has warmed up, the main motor and fans stop turning.
10. "Ready" appears on the display.

Device Tests

Quick Disk Test

This test performs a non-destructive read/write on one block per track on the disk. The test reads one block on each track, saves the data, and proceeds to write and read four test patterns to the bytes in the block. If the block is good, the saved data is written back to the disk.

To run the Quick Disk Test:

1. Select the Quick Disk Test from the Device Tests menu.
 - The busy indicator flashes while the test is in progress.
 - "Quick Disk Test/Test Passed" message displays if the test passes and the busy indicator turns on solid.
 - "Quick Disk Test/Test Failed" message displays if the test failed and the busy indicator turns on solid.
2. Press Go, Return, or Stop to return to the Device Tests menu.

Disk Test/Clean

WARNING: This test destroys all data on the disk and should not be attempted on a good disk. Also note that this test may run approximately 1 1/2 hours depending on the disk size.

To run the Disk Test/Clean Test:

1. Select Disk Test/Clean from the Device Tests menu.
 - “Files will be lost/Go or Stop?” message displays to warn the user that all contents on the disk will be lost.
2. To exit the test immediately and return to the Device Tests menu, press Return or Stop. To continue with the test, press Go.
 - If go is selected, “Cleaning Disk/BAD:000000 00%” message displays. The screen updates periodically indicating the percentage of test completed and the number of bad blocks found.
3. The busy indicator flashes during the test. The test can be canceled anytime during the test by pressing Return or Stop.
 - Once the test is complete, the busy indicator turns on solid and a message displays.
 - “xxxx Bad Blocks/yyyyy Usable” message displays if fewer than 2000 bad blocks are detected. xxxx indicates the number of bad blocks and yyyyyy indicates the number of usable blocks.
 - “xxxx Bad Blocks/Replace Disk” message displays if more than 2000 bad blocks are detected. The disk cannot be recovered because too many bad blocks exist on the disk.
4. Press Go or Return or Stop to return to the Device Tests menu.

Flash Test

This test causes the file system to write and read data on the flash to test the flash.

WARNING: This test destroys all data on the flash because the flash is reformatted at the end of the test.

To run the Flash Test:

1. Select Flash Test from the Device Tests menu.
 - The busy indicator flashes while the test is running.

- “Flash Test/Test Passed” message displays if the test passes and the busy indicator turns on solid.
 - “Flash Test/Test Failed” message displays if the test fails and the busy indicator turns on solid.
2. Press Go or Return or Stop to return to the Device Tests menu.

Disabling Download Emulations

Error Code 964: Download Emulation CRC Failure. Checksum failure detected in the emulation header or emulation file.

Error Code 965: Download Emulation Outdated. Time stamps indicate the download emulation and RIP code are incompatible.

To help resolve Download Emulation problems the following steps are necessary to instruct the printer to POR without activating any download emulations.

To Disable the Download Emulation:

1. Turn the printer off.
2. Press and hold the Go and Menu+ buttons.
3. Turn the printer On and release the buttons once “Performing Self Test” displays.
 - Once the printer is idle, the emulation can be downloaded again.
4. Program the download emulation into the code overlay SIMM again.
5. If these steps do not resolve the problem, replace the code overlay SIMM and download the emulation again.

Error Log

Viewing the Error Log

The error log is helpful to the servicer by providing a history of printer errors. The error log contains the 12 most recent errors that have occurred on the printer. The most recent error displays in position 1 and the oldest error displays in position 12 (if 12 errors have occurred). If an error occurs after the log is full, the oldest error is

discarded. Identical errors in consecutive positions in the log are entered. All 2xx and 9xx error messages are stored in the error log.

To view the Error Log:

1. Select Display Log from the Error Log menu. The Error log displays on 3 screens as only 4 entries display at a time.
2. To move to the next screen press Menu+ to move forward or Menu- to move backward.
3. Press Return or Stop to exit the Error Log.

Clearing the Error Log

To clear the Error Log:

1. Select Clear Log from the Error Log menu.
2. Select "YES" to clear the Error Log or "NO" to exit the Clear Log menu. If "YES" is selected, the Empty Error Log displays on the screen.
3. Press Return or Stop to exit the Clear Log menu.

Hardware Tests

The following Hardware Tests can be selected from this menu:

- LCD Test
- Button Test
- DRAM Memory Test
- ROM Memory Test
- Parallel Wrap (if available)
- Serial Wrap (if available)

LCD Test

To run the LCD Test:

1. Select LCD Test from the Diagnostic menu. The LCD test continually executes the LCD display test.
2. Press Return to cancel the test.

Button Test

To run the Button Test:

1. Select Button Test from the Diagnostic menu. With no buttons pressed several OP (Open) appear on the display.
2. Press each button one at a time and a CL (Closed) displays in place of an OP. The proper operation of each button can be checked.
3. Press Return or Stop to cancel the test.

DRAM Memory Test

The purpose of this test is to check the validity of DRAM, both standard and optional. The test writes patterns of data to DRAM to verify that each bit in memory can be set and read correctly.

To run the DRAM Memory Test:

1. Select DRAM Memory Test from the menu. The busy indicator flashes indicating the test is in progress.
2. Press Return or Stop to exit the test.

P:##### represents the number of times the memory test has passed and finished successfully. Initially 000000 displays with the maximum pass count being 999,999.

F:##### represents the number of times the memory test has failed and finished with errors. Initially 000000 displays with the maximum fail count being 99,999.

Once the maximum pass count or fail count is reached, the test is stopped, the power indicator is turned on solid, and the final results display. If the test fails, the message DRAM Error, displays for approximately 3 seconds and the failure count increases by 1.

ROM Memory Test

The ROM Memory Test is used to check the validity of the RIP code and fonts.

To run the ROM Memory Test:

1. Select ROM Memory Test from the menu. P and F represent the

same numbers for DRAM. The busy indicator flashes indicating the test is in process. The test runs continuously.

2. Press Return or Stop to exit the test.

Each time the test finishes, the screen updates with the result. If the test passes, the Pass Count increases by 1, however if the test fails, one of the following messages displays for approximately 3 seconds:

ROM Checksum Error
ROM Burst Read Error

Once the maximum pass count or fail count is reached, the test stops with the busy indicator on solid. The final results display on the screen.

Parallel Wrap Test

This test is used with a wrap plug to check operation of the parallel port hardware. Each parallel signal is tested.

To run the Parallel Wrap Test:

1. Disconnect the parallel interconnect cable and install the wrap plug (P/N 1319128).
2. Select the Parallel Wrap Test from the Hardware Tests menu. The busy indicator flashes indicating the test is in progress. The test runs continuously until canceled.

Each time the test finishes, the screen updates. If the test passes, the Pass Count increases by 1, however if the test fails, one of the following messages displays for approximately 3 seconds:

Sync Busy Error
Byte Interrupt Request Error
Strobe Interrupt Request Error
Init Fail Error
Init Busy Error
Init Rise Error
Host Busy Error
RAM Data FF Error
RAM Data AA Error
RAM Data 00 Error

RAM Data 55 Error
DMA Count Error
DMA Address Error
DMA Interrupt Error
DMA Memory Error
DMA Background Error
Clear Init Rise Error
False Init Rise Error
False Init Fall Error
Autofeed Rising Interrupt Error
Clear Autofeed Rise Error
False Autofeed Rise Error
Autofeed Falling Interrupt Error
Clear Autofeed Fall Error

Once the maximum count is reached the test stops. The busy indicator goes on solid and the final results display.

Press Return or Stop to exit the test.

Serial Wrap Test

This test is used to check the operation of the Serial Port Hardware using a wrap plug. Each signal is tested.

To run the Serial Wrap Test:

1. Disconnect the serial interconnect cable and install the serial wrap plug.
2. Select the appropriate Serial Wrap Test from the menu: Serial Wrap, Serial 1 Wrap. The busy indicator flashes indicating the test is running.

P:##### represents the number of times the memory test has passed and finished successfully. Initially 000000 displays with the maximum pass count being 999,999.

F:##### represents the number of times the memory test has failed and finished with errors. Initially 00000 displays with the maximum fail count being 99,999.

3. This test runs continuously unless canceled by pressing Return or Stop.

Each time the test finishes, the screen updates with the result. If the test passes, the Pass Count increases by 1, however if the test fails, one of the following failure messages displays for approximately 3 seconds and the Fail Count increases by 1:

- Receive Status Interrupt Error
- Status Error
- Receive Data Interrupt Error
- Transmit Data Interrupt Error
- Transmit Empty Error
- Threshold Error
- Receive Data Ready Error
- Break Interrupt Error
- Framing Error
- Parity Error
- Overrun Error
- Data Error
- Data 232 Error
- Data 422 Error
- FIFO Error
- DSR Error
- DSR PIO Error
- DSR Interrupt Error
- CTS Error
- CTS PIO Error
- CTS Interrupt Error

Once the maximum count is reached the test stops. The busy indicator goes on solid and the final results display.

Press Return or Stop to exit the test.

Input Tray Tests

Input Tray Feed Test

This test lets the servicer observe the paper path as media is feeding through the printer. A blank sheet of paper feeds through the printer as the laser turns off during this test. The only way to observe the paper path is to open the lower front door that is used to access the multipurpose feeder. The paper is placed in the output bin.

To run the Input Tray Feed Test:

1. Select Input Tray Feed Test from the menu.
2. Select the input source from the sources displayed on the Feeds Test menu. All installed sources are listed.
3. Select either Single (feeds one sheet of media from the selected source) or Continuous (continues feeding media from the selected source until Return or Stop is pressed).
4. Press Return or Stop to exit test.

Input Tray Sensor Test

This test is used to determine if the input tray sensors are working correctly.

To run the Input Tray Sensor Test:

1. Select the Sensor Test from the Input Tray Tests menu.
2. Select the input source from the sources displayed on the Sensor Test Menu
 - "Input Tray/EM=xx Size=xxx" displays.
 - EM = Input Tray Empty Sensor
 - Size = Input Tray Size Sensor
3. Once this message displays, you can manually actuate each sensor. To view a valid EM sensor value, you must manually press the paper size sensor tabs to select a valid tray size. If you do not select a valid tray size, the empty tray sensor will display ?? and the size sensor will display - - -. When the tray is out of paper, the empty tray sensor closes and EM=CL displays. When the tray contains paper, the empty tray sensor is open and EM=OP displays.

4. Press Return or Stop to exit the test.

The multipurpose tray does not have a paper low sensor.

Base Sensor Test

This test is used to determine if the sensors located inside the printer are working correctly.

The following sensors can be checked:

- Standard Bin Full
- Upper Front Door Open
- Rear Door Open (paper guide)

To run the Base Sensor Test:

1. Select the sensor you want from Base Sensor Test. The operator panel displays OP for open and CL for closed.
2. Manually toggle the sensors by hand to verify that each sensor switches from open to closed. The standard bin sensor requires about six seconds to activate.
3. Press Return or Stop to exit the test.

Print Registration

The print registration range is as follows:

- Bottom Margin: -7 to +8
- Top Margin: -20 to +20
- Left Margin: -23 to +23
- Manual Top: -20 to +20

To set Print Registration:

1. Select Registration from the Diagnostic menu.
2. The Top margin sign/value pair flashes. This indicates it is the margin value being changed.
3. To select the margin value to be changed press Select until the margin value pair you want to change is blinking.
4. To change the margin value press either Menu+ or Menu-.

When the value you want is displayed, press Select to save the value.

5. To exit the Registration menu, press Return.

To verify the margin values are correct you must print the "Quick Test Page" from the registration screen. Press Go to print the test page. While printing the Quick Test Page the "Quick Test Printing" message displays. Once the Quick Test Page completes printing, the Registration screen displays again.

The "Quick Test Page" should be printed on letter or A4 paper.

Printer Setup

Setting the Page Count

This lets the servicer change the page count from the diagnostic menu. This is used whenever the engine board is replaced because this board contains the printer's NVRAM Memory where the page count is stored.

To set the Page Count:

1. Select Page Count from the Diagnostic menu.
 - The current page count displays.
 - The leftmost digit flashes, indicating it is the first digit to be changed.
2. Press either Menu+ or Menu- until the value you want displays.
3. Press Select to move to the next digit, press Menu+ or Menu- until the value you want displays. Continue with each digit until you set the page count. You can press Select to skip a digit. When you press Select after the final digit, the new page count is stored in NVRAM.
4. Press Select to save the new page count in NVRAM.
5. Press Return to exit the Diagnostic menu.

Viewing the Permanent Page Count

The Permanent Page Count can only be viewed and cannot be changed.

To view the Permanent Page Count:

1. Select Permanent Page Count from the menu.
2. Press Return to exit the diagnostic menu.

Setting Configuration ID

The configuration ID is used to communicate information about certain areas of the printer that cannot be determined using hardware sensors. The Configuration ID is originally set at the factory when the printer is manufactured, however it requires resetting whenever you replace the engine board and can be set on the operator panel. However the Configuration ID is the only diagnostic function displayed until a valid ID is entered.

To set the Configuration ID:

1. Select Configuration ID from the Printer Setup menu.
 - The current ID displays on the screen. The Configuration ID for the 4046-001 is 000303. The ID code for other models with different configurations is on a label located on the controller board cage. Remove the right cover and open the card cage to see the label.
 - The leftmost digit flashes indicating that it is the first digit to be changed.
2. To change the value, press either Menu+ or Menu- until the value you want is reached. Press Select to move to the next digit, or press Select again to skip a digit. Change each digit as required. When the last digit is changed, press Select to validate the Configuration ID. If the ID is invalid then "INVALID ID" message displays on Line 2 before the ID displays again. You have to reenter the Configuration ID until a valid ID is verified. If the ID is valid then the ID is saved in NVRAM and the printer automatically PORs to activate the new setting.

Note: When the printer PORs it does so in the normal mode.

Print Tests

The purpose of the diagnostic Print Tests is to verify that the printer can print on media from each of the installed input options. Each of the installed options is listed in the following order in the menu:

- Tray 1
- Tray 2 (if installed)
- Multipurpose Feeder (if installed)

For each input source selected you have the following choice:

- Single (prints the Print Test Page once)
- Continuous (continue printing the Print Test Page until Return or Stop is pressed).

The contents of the Print Test Page varies depending on the media installed in the selected input source.

To run the Print Test Page:

1. Select Print Tests from the Diagnostic menu.
2. Select the media source.
3. Select Single or Continuous.
 - If single is selected no buttons are active during printing.
 - If continuous is selected, Return or Stop can be selected to cancel the test.

Check each Test Page from each source to assist in Print Quality and Paper Feed problems.

Print Quality Test Pages

The purpose of this diagnostic function is to allow printing of the print quality test pages with the toner cartridge lockout function disabled. The print quality test consists of three pages. Page one contains a mixture of graphics and text. Pages two and three only contain graphics. The Print Quality Test pages must always be printed on letter, legal or A4 paper.

To run the Print Quality Test Pages, select Print Quality Pages from the diagnostic menu or follow these steps:

1. Turn the printer off.
2. Press and hold Select and Return.
3. Turn on the printer.
4. Release the buttons once Performing the Self Test displays.
5. The printer performs its normal POR cycle then print one copy of the Print Quality Test pages. If you want more than one copy, perform these steps again.

The following is printed on page 1:

- Contents of the Diagnostic Error Log.
- Printer configuration information: printer serial number, controller code level, engine code level, operator panel code level, margin settings, smart option code levels, font versions, and so on.
- Values for the Quality Menu settings used to print the pages.

Printing Menu Settings Page

Note: This test page must be printed on letter, legal or A4 paper.

To print the Menu Settings Page:

1. Select the TESTS MENU.
2. Select Print Menus from the TESTS MENU.

The page contains the following information:

- A list of all the printer settings contained in the control panel menus and their values.
- A list of the installed options and features such as RAM memory SIMMs, optional input paper trays, duplex, flash or disk.
- Printer information such as serial number, page count, installed RAM, engine code level, RIP code level, control panel code Paper Feed Jams

Paper Jams - Base Printer

Error Message 200 - Paper Jam - Remove Print Unit

This message indicates that paper is jammed at the printer input sensor. This condition can be caused by the paper jamming prior to activating the input sensor flag, the sensor not detecting paper over the sensor or paper arriving at the sensor too late.

Error Message 201 - Paper Jam - Remove Print Unit

This message indicates the paper is jammed between the printer's input and exit sensors. This condition can be caused by the paper exiting the input sensor too late or jamming in the fuser assembly prior to activating the exit sensor flag in time or not at all.

Error Message 202 - Paper Jam - Open Rear Door

This message indicates the paper is jammed at the printer exit sensor. This can be caused by the paper arriving at the sensor too late, the paper is jammed in the fuser assembly or is jammed exiting the fuser assembly in the redrive assembly.

Paper Jams - Options

Error Message 240 (Tray 1) or 242 (Tray 2)

The paper has not cleared the pass through sensor or reached the pass through sensor of the option above tray 1 or tray 2.

If "Tray Feeder" is displayed, the paper may have jammed prior to reaching the input sensor. The paper may be in the tray, paper feed path from tray to the input sensor, or in the Multi-function feeder.

4. Repair Information

Precautions for Disassembly and Cleaning

Observe the following precautions whenever you service the printer:

- Be sure to unplug the printer from the outlet before attempting to service the printer.
- To reassemble the printer, reverse the order of disassembly unless otherwise specified.
- The basic rule is not to operate the printer anytime during disassembly. If it is absolutely necessary to run the printer with its covers removed, use care not to allow your clothing to be caught in revolving parts such as the gears, rollers and fan motor.
- Never touch the terminals of electrical parts or high-voltage parts such as the high voltage unit.
- Be sure to handle the fuser carefully as it remains hot for a while after the printer stops running. Always unplug connectors by holding the connector housing.
- Be sure to use the fuse of the specified rating.
- Do not forget to install the ground wire or ground plate to ensure positive conduction. Install the screw with a toothed washer in the right position at reassembly.

Instructions for Handling the PWBs with MOS ICs

The following precautions must be observed when handling circuit boards with MOS (Metal Oxide Semiconductor) ICs.

During Transportation/Storage:

- During transportation or when in storage, new circuit boards must not be indiscriminately removed from their protective conductive bags.
- Do not store or place circuit boards in a location exposed to direct sunlight.
- When it becomes absolutely necessary to remove a board from its conductive bag or case, always place it on its conductive mat in an area as free as possible from static electricity.
- Do not touch pins of the ICs with your bare hands.

During Replacement:

- Before you unplug connectors from the circuit boards, be sure the power cord has been unplugged from the power outlet.
- When you remove a board from its conductive bag or case, do not touch the pins of the ICs or the printed pattern. Place it in position by holding only the edges of the board.
- Before you plug connectors into the board, be sure the power cord has been unplugged from the power outlet.

During Inspection:

- Avoid checking the IC directly with a multimeter; use connectors on the board.
- Never create a closed circuit across IC pins with a metal tool.
- When it is absolutely necessary to touch the ICs and other electrical components on the board, be sure to ground your body.

Precautions for Handling the Drum Cartridge

The following precautions must be observed when handling the drum cartridge:

During Transportation/Storage:

- Use the specified carton whenever moving or storing the drum cartridge.
- The storage temperature is in the range between -20°C and $+40^{\circ}\text{C}$.

Handling:

- The PC drum in the drum cartridge exhibits greatest light fatigue after being exposed to strong light over an extended period of time. Never, therefore, expose it to direct sunlight.
- Use care not to contaminate the surface of the PC drum with oil-base solvent, fingerprints, and other foreign matter.
- Do not scratch the surface of the PC drum.

Parts not to be touched

Any part where the mounting screws are painted red, such as the printhead, must not be removed, disassembled or adjusted.

Precautions for Handling the Laser Equipment

- When a service job needs to be performed in the laser beam path, such as when working around the printhead and the drum cartridge, be sure to turn the printer off first.
- A highly reflective tool can be dangerous if it is brought into the laser beam path. Use utmost care when handling tools around the laser beam.
- If the job requires that the printer be left on, take off your watch and ring, and wear laser protective goggles which must meet the following laser specifications:
 - Max. power: 5mW
 - Output wavelength: 780 - 810nm

Removal Procedures

Do not disassemble the following parts:

- Printhead
- Toner Bottle
- Fuser
- Transfer Corona Assembly

Control Board Removal

1. Remove the right side cover.
2. Remove the outer shield.
3. Disconnect the controller board cable from J4.
4. Remove the two parallel port screws.
5. Remove the back connector panel cover (3 screws).
6. Remove the 5 screws that hold the controller board in place.
7. As you remove the controller board, tilt the top of the board away from the printer in order to clear the inner shield.

Cover Removal

1. Open the upper door.
2. Remove the three screws from the upper cover.
3. Remove the rear cover (1 screw).

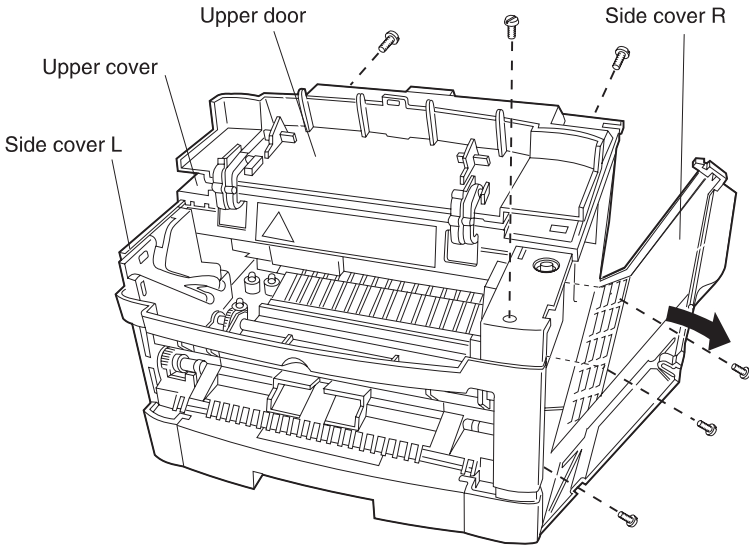

4. Remove the left and right side covers.

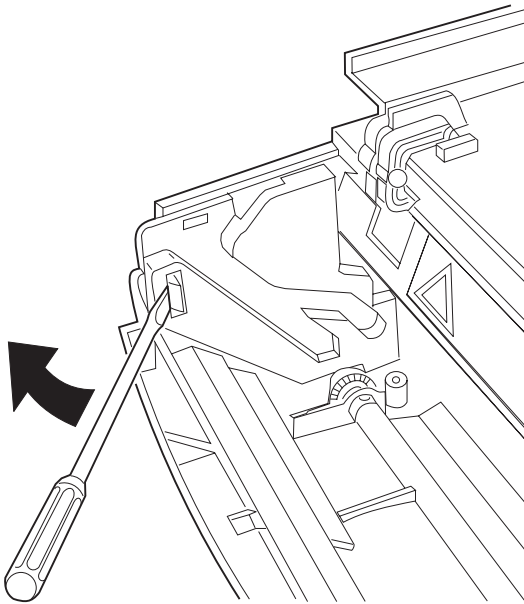

5. Use a screwdriver to release the latches on the left side of the upper cover as you lift the cover upward. As you lift the cover, disconnect the print density cable and operator panel cable from the operator panel.

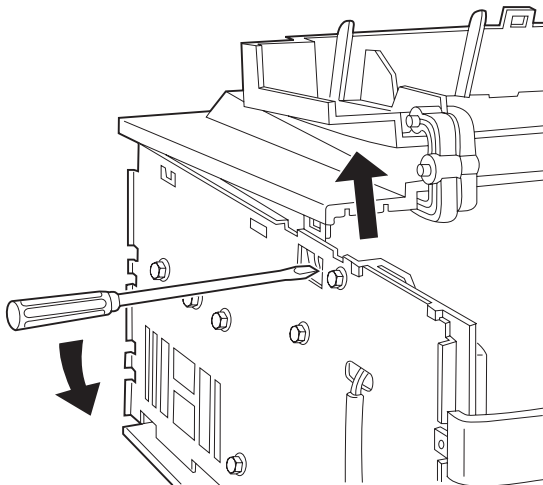

Cover-Open Switch Removal

1. Remove the interconnect board and the high voltage power supply.
2. Disconnect the cover-open switch connector.
3. Disengage the two latches of the left guide and pull the left guide upward to remove it.
4. Remove the cover-open switch.

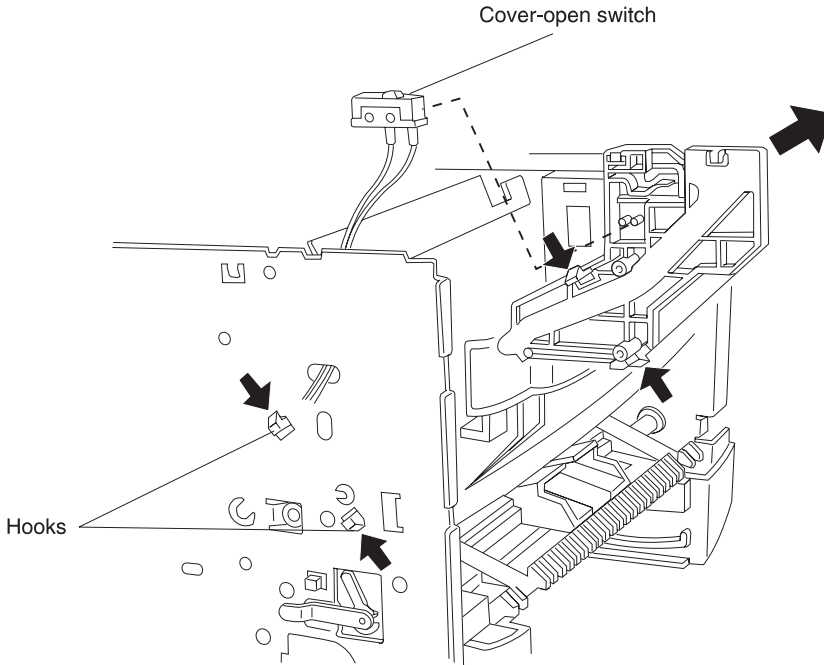

Installation Note: When you install the new switch, place the switch in the left guide then carefully slide the guide along the metal frame into position.

Engine Board Removal

1. Remove the right side cover.
2. Open the controller board door assembly.
3. Disconnect all connectors from the engine board, except for the lower control board cable (connectors CNCA and CNCB).
4. Remove the two screws and disengage the hook on the left side of the card.
5. Remove the engine board from the printer and disconnect the lower control board cable (connectors CNCA and CNCB).

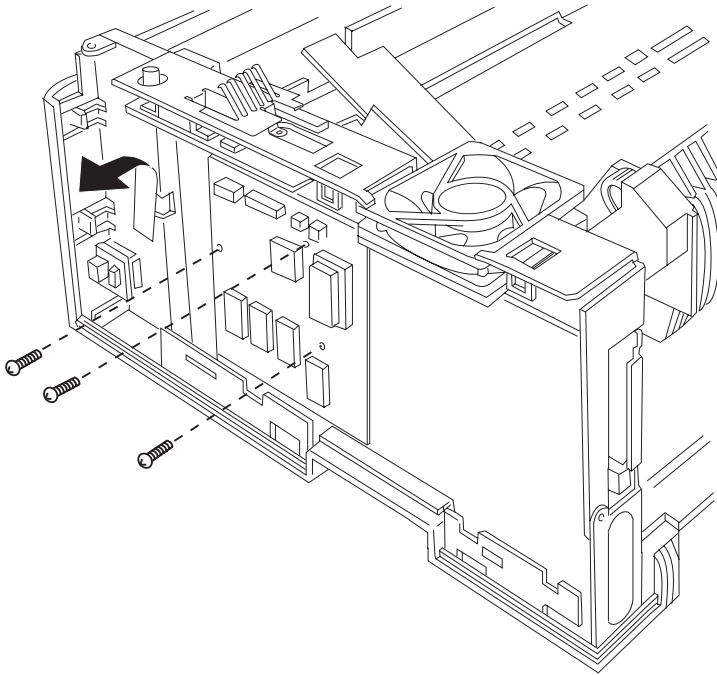

Installation Notes:

1. There is a connector on the back side of the engine board which connects the interconnect board. When you install the engine board, position it so the engine board connector faces the interconnect board connector.
2. The white connector with red and blue cables connects to the white jumper (CNF1). The blue connector with red and black cables connects to the blue jumper (CNF2).

Engine Fan Removal

1. Remove the right side and the upper cover.
2. Open the controller card door assembly.
3. Remove the fan shield plate.
4. Disconnect the engine fan and pull the cable through the toroid.
5. To remove the fan, lift it at an angle as you press the lower mounting plate down with a screwdriver.

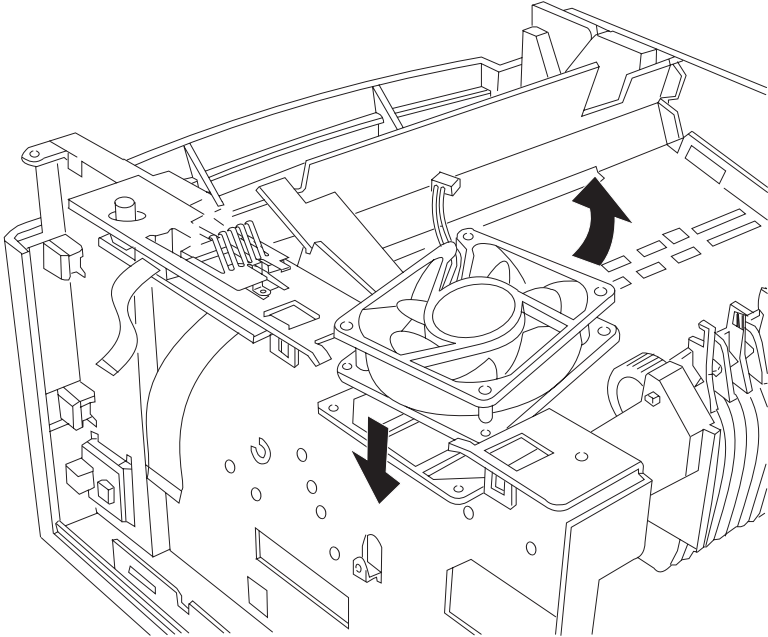

Installation Note: Install the fan so the air flow arrow is facing up.

Exit Paper Feed Roller Assembly Removal

1. Remove the right side cover.
2. Open the controller board cage door assembly and disconnect the process fan from the engine board.
3. Remove the fuser and power supply board assembly.
4. Remove the paper feed guide assembly.
5. Remove the process fan/plate assembly (2 screws).
6. Remove the six gears.
7. Remove the right side paper feed frame.
8. Remove the exit paper feed roller assembly.

Installation Note:

1. To prevent damage to the pick motor cable and cover open switch cable be sure they are placed above the interconnect card.
2. Return the gears to the original position and install the process fan/plate assembly to hold them in place.
3. Be sure to fasten the fan to the plate so the air flow arrow is in the outward direction.

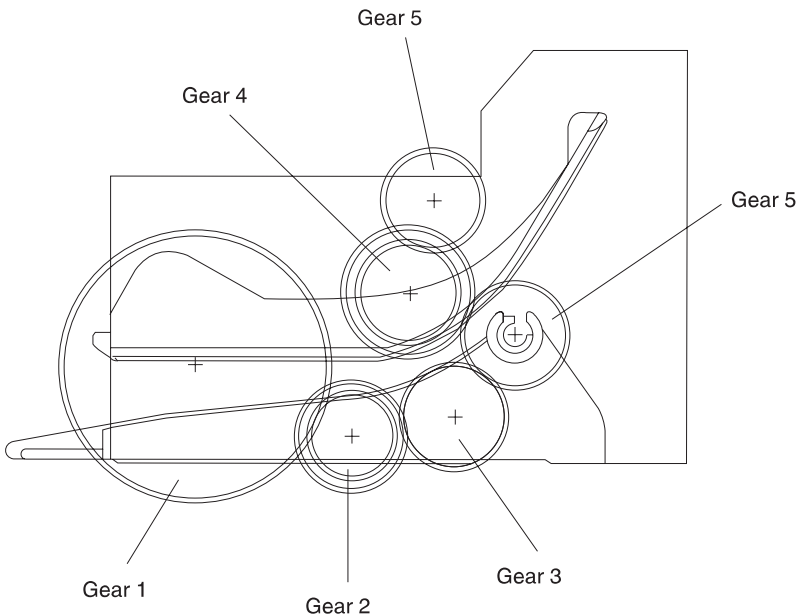

Fuser Removal

1. Remove the right side cover.
2. Open the controller card door assembly and remove the fan shield plate.
3. Disconnect the process fan from the engine card and pull it through the toroid.
4. Remove the rear cover.
5. Remove the rear stacker.

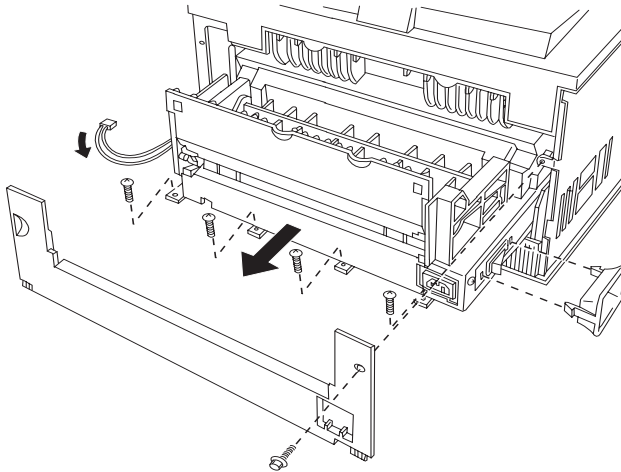

6. The power supply board and the fuser could be hot. Be careful when you remove them in this step. Remove the four screws from the rear of the machine and slide the fuser and power supply board assembly out the rear of the printer. Be careful not to damage the pick motor cable when removing the fuser and power supply board assembly.
7. Disconnect the two connectors from the power supply board.
8. Turn the fuser assembly bottom side up, and remove the six screws from the power supply board, lifting the power supply board from the fuser assembly.
9. Disconnect the remaining connector from the power supply board, removing the board.
10. Remove the two screws securing the process fan to the bracket and remove the fan.

High Voltage Power Supply Board and Interconnect Board Removal

1. Remove the paper tray.
2. Remove the right side cover and the control board cage door.
3. Remove the engine board.
4. Remove the four screws from the bottom of the printer to remove the interconnect board/HVPS assembly.

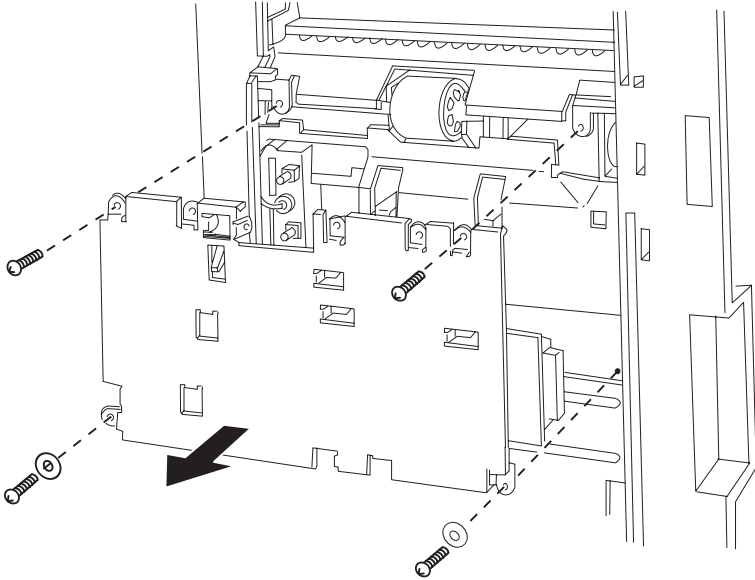

5. Remove five screws to remove the interconnect board.
6. Remove three screws to remove the high voltage power supply board.

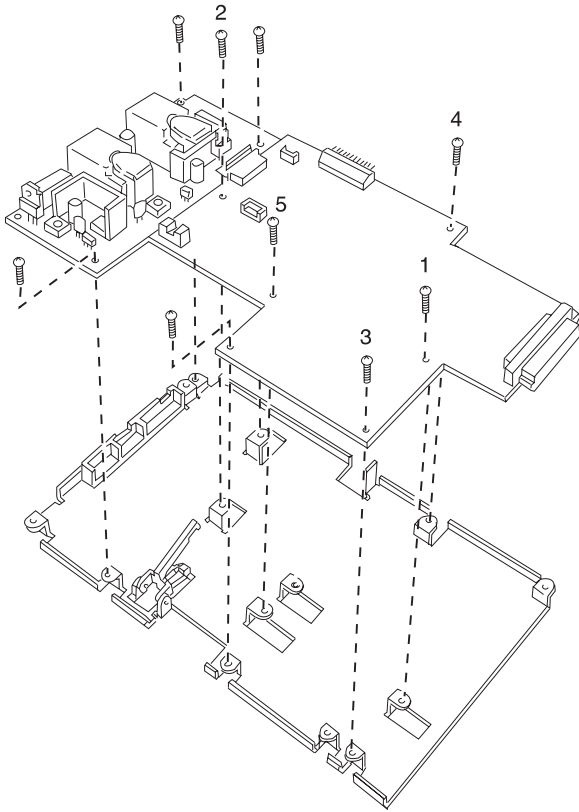

Installation Notes:

1. When you install the interconnect board, observe the order of fastening screws as shown above.
2. When you install the high voltage power supply/interconnect board assembly, be careful the cable does not overlap the four spring electrodes on the bottom left of the printer mechanism.
3. As you install the HVPS/interconnect board assembly, be sure the interconnect board connects into the power supply board. Be sure to match the four screw positions.

Main Motor Removal

1. Remove the right side and upper cover.
2. Open the controller board cage door assembly.
3. Remove the fan shield plate.
4. Remove the engine cooling fan.
5. Remove the engine board.
6. Remove the main motor assembly (4 screws).

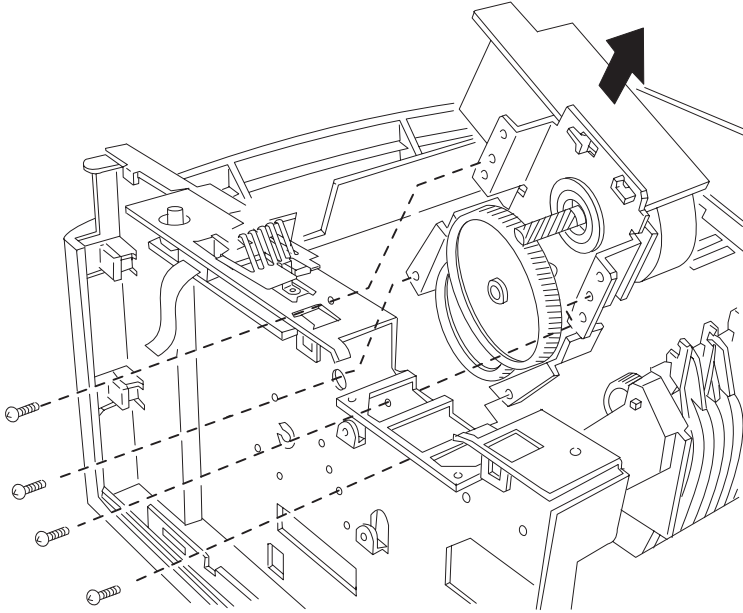

7. Remove four screws and disconnect the cable to remove the main motor.

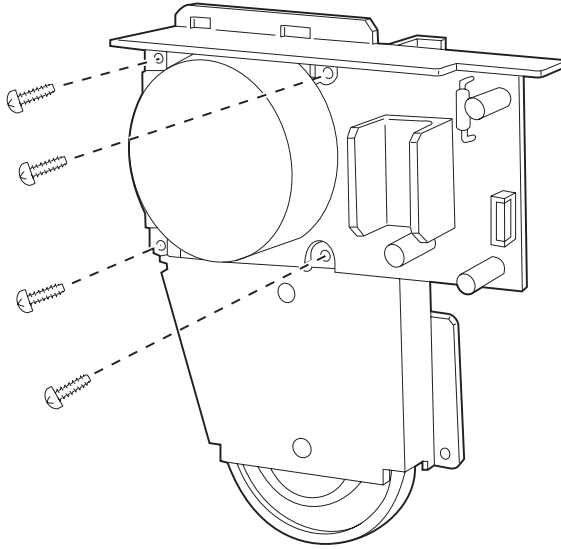

Multi-Function Feeder Board Removal

1. Remove the right side cover.
2. Disconnect the cable from the MFF board.
3. Remove the board (1 screw).

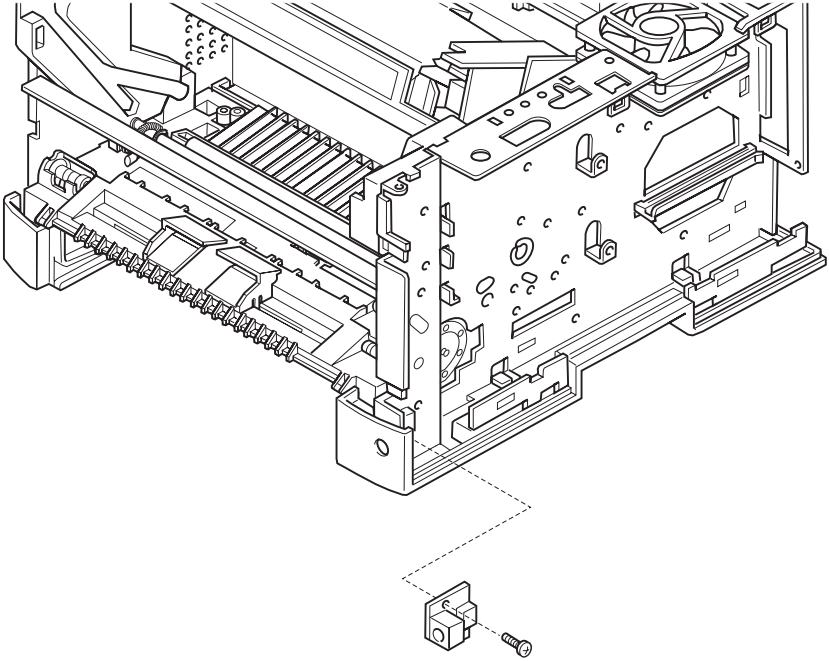

Paper Feed Motor Removal

1. Remove the right side cover.
2. Open the controller board cage door assembly.
3. Disconnect the controller board cable and remove the controller board door assembly.
4. Remove the engine board.
5. Remove the fan shield plate.
6. Remove the fixed hinge bracket.
7. Remove the 2 mounting screws and pull out the paper feed motor.

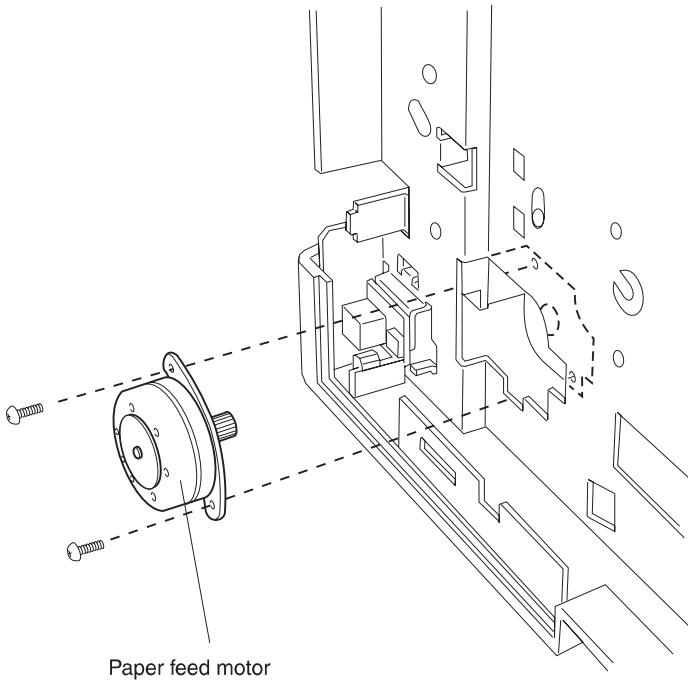

Paper Feed Roller Removal

1. Remove the upper cover and the left and right side covers.
2. Remove three screws, disengage three hooks, and disconnect the toner sensor connector to remove the upper front cover assembly.

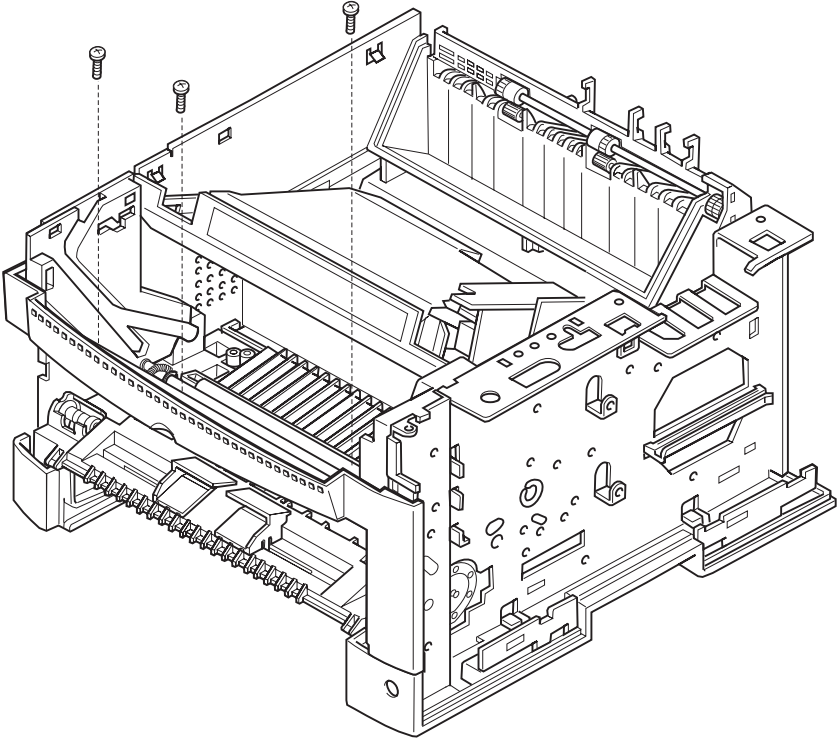

3. Remove the right and left springs and lift the upper feed roll from the paper feed frame.
4. Peel off the two guide sheets (Mylar films). Be sure to completely remove the double-sided adhesive tape.
5. Use a screwdriver to disengage the bearing phase shift levers at both ends of the lower feed roll, and raise the lever upward to

remove the lower feed roll.

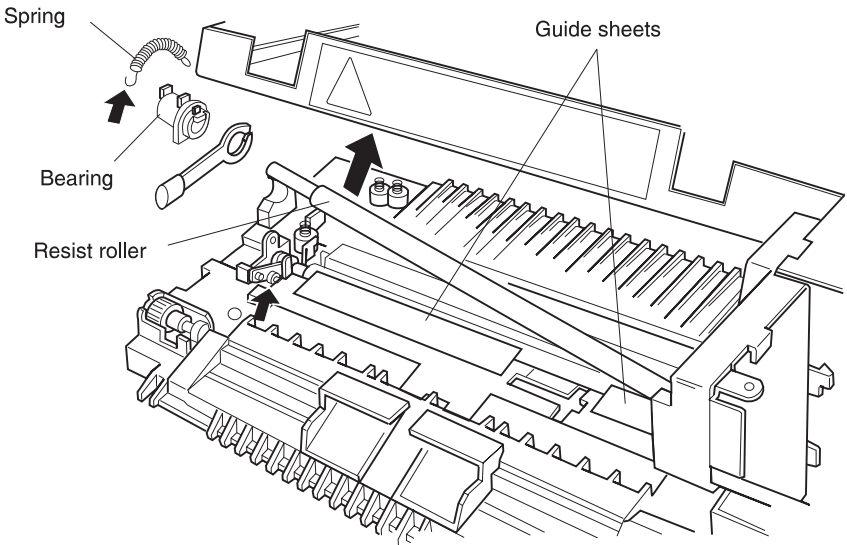

6. Use diagonal cutting pliers to cut the hook off the gear at the right end of the lower feed roll.
7. Move the lower feed roll to the left and pull out the roller from the left end.

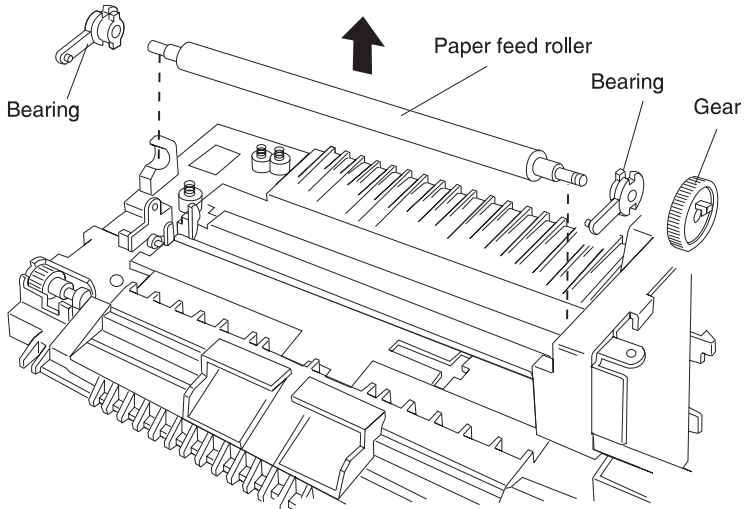

Installation Note:

1. When you install the lower feed roll:
 - a. Insert the right end D-cut of the lower feed roll into the hole of the right bearing, then the hole of a new gear until the gear is caught by the hook.
 - b. Fit the other bearing to the left end (the end without a D-cut) of the lower feed roll.
 - c. Insert the bearings into guide grooves on the base frame with the bearing phase shift levers set upward. Turn the bearing levers to the initial state positions to secure the bearings to the base frame.
2. Adhere new guide sheets to the base frame: longer one to the left area and shorter one to the right area. Be sure there is no clearance between the adhesive tape and the positioning edge.

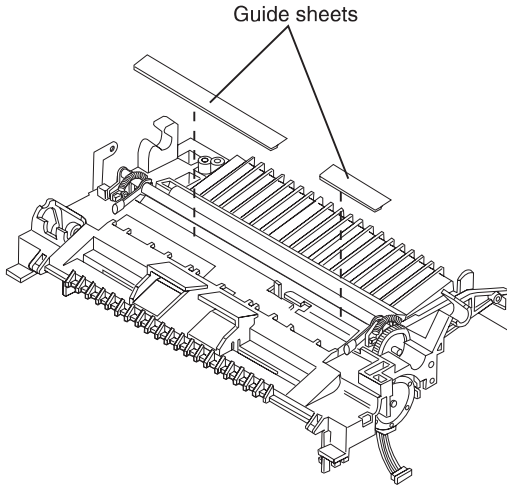

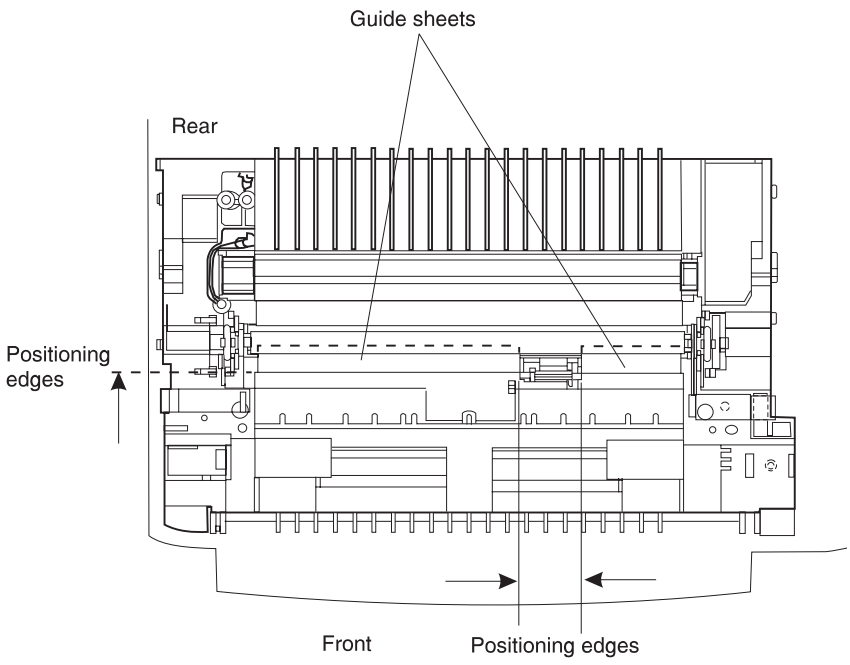

Pick-up Motor Removal

1. Remove the paper tray.
2. Remove the left side cover.
3. Remove the left paper tray guide assembly.
4. Remove the interconnect board and high voltage power supply assembly.
5. Remove the pick-up motor, (2 screws).

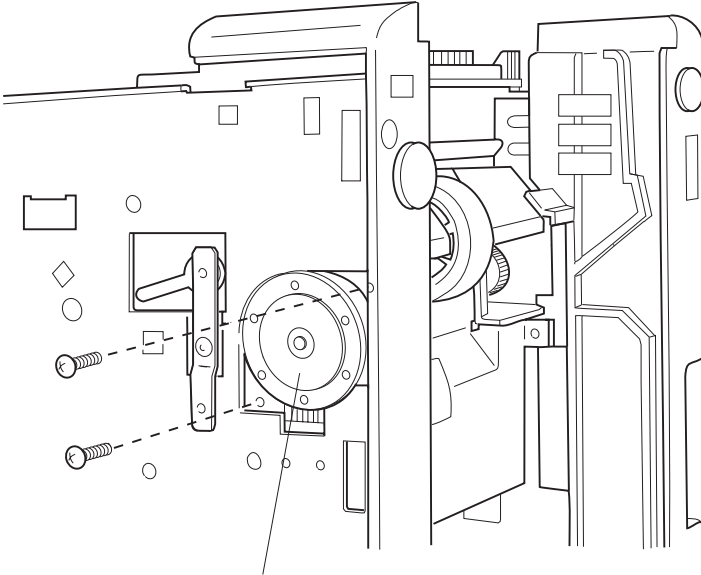

Pick-up motor

Pick-up Roller Removal

1. Remove the paper tray.
2. Remove the left side cover.
3. Remove the screw from the pick-up roller shaft ground plate and remove the ground plate.
4. Use a screwdriver to remove the bearing.
5. Pull the pick-up roller shaft out approximately 50 mm to remove the pick-up roller. Do not pull the shaft out completely.

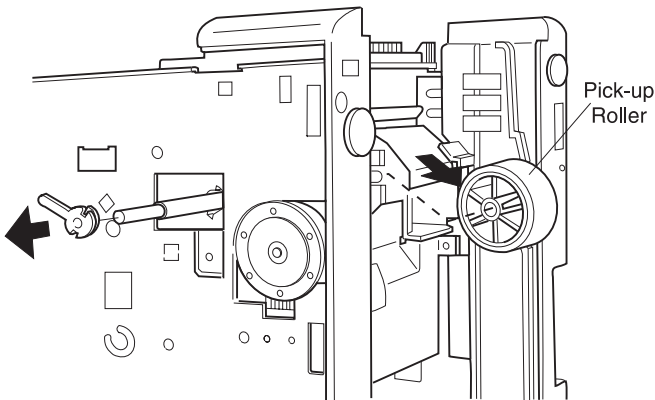
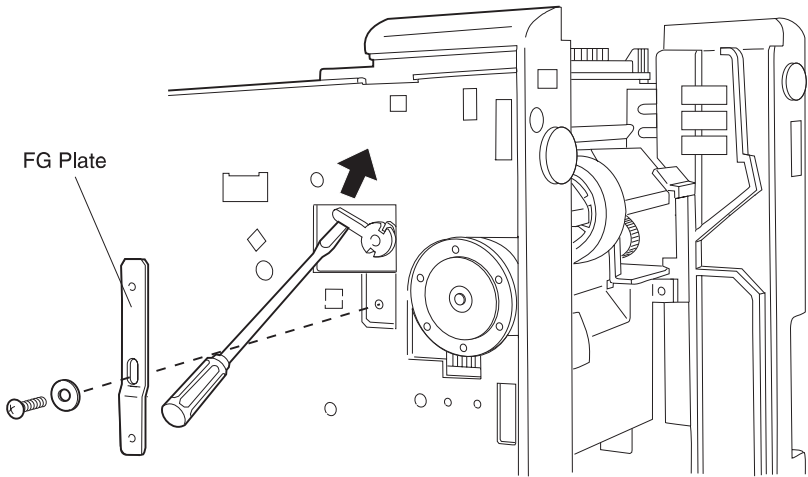

Installation Note:

When you put the pick-up roller on the shaft, face the tapered rib of the roller toward the pick-up motor.

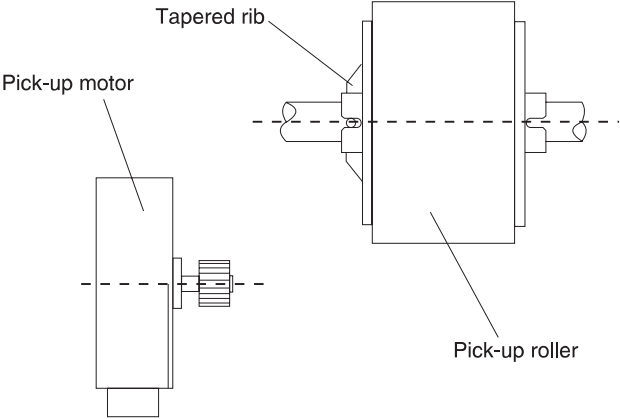

Power Supply Board Removal

1. Remove the right side cover and the shield plate.
2. Open the controller card door assembly and disconnect the process fan.
3. Remove the fuser and power supply board assembly.
4. Turn the assembly upside down.
5. Remove the six screws that hold the power supply board in place.
6. Disconnect the two fuser connectors, then the sensor board connector, and remove the power supply board.

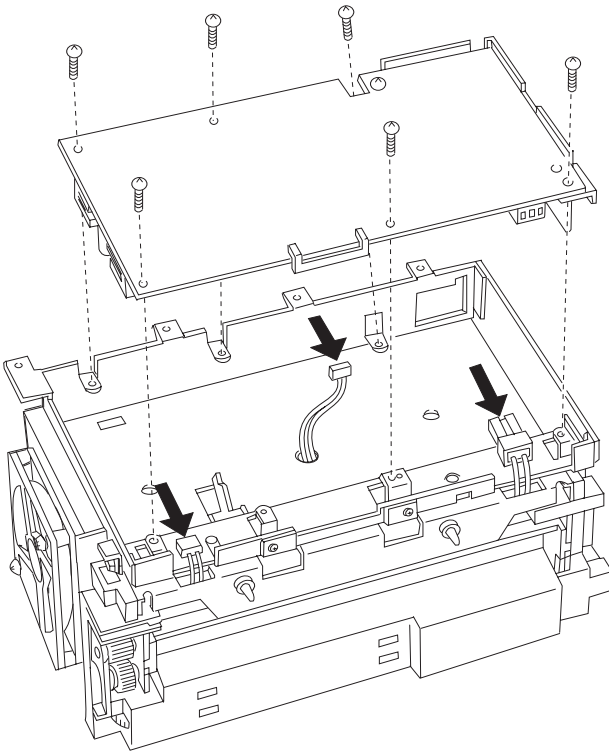

Installation Note: To prevent damage to the pick motor cable and cover open switch cable be sure they are above the interconnect card.

Print Density Board Removal

1. Remove the control board.
2. Remove the fan shield plate.

Remove the print density board from the bottom of the frame (1 screw).

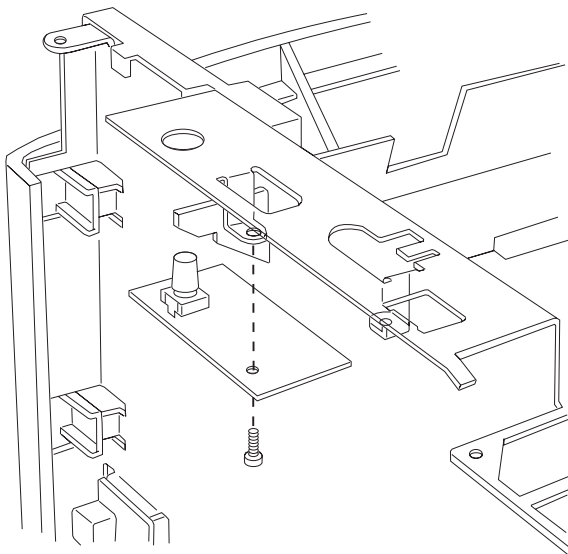

Printhead Removal

1. Remove the upper cover.
2. Disconnect the connector from the printhead assembly.
3. Remove the printhead cover and the printhead assembly (3 screws).

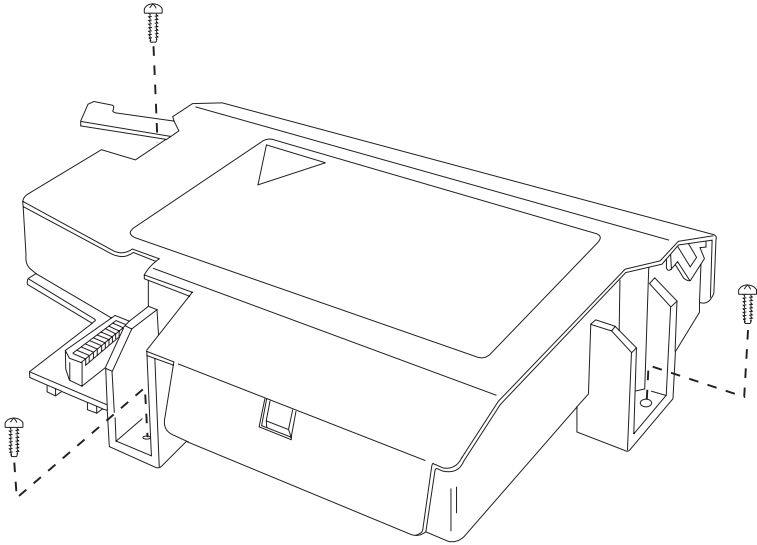

Printhead Erase LED Assembly Removal

1. Remove the upper cover.
2. Remove the printhead.
3. Open the controller card door assembly.
4. Disconnect the printhead erase LED assembly cable from the engine card.
5. Pull the ends of the printhead erase LED assembly forward to unlatch it from the frame assembly.
6. Remove the printhead erase LED assembly.

Process Fan Removal

1. Remove the fuser and power supply assembly.
2. Remove the fan from the side of the assembly (2 screws).

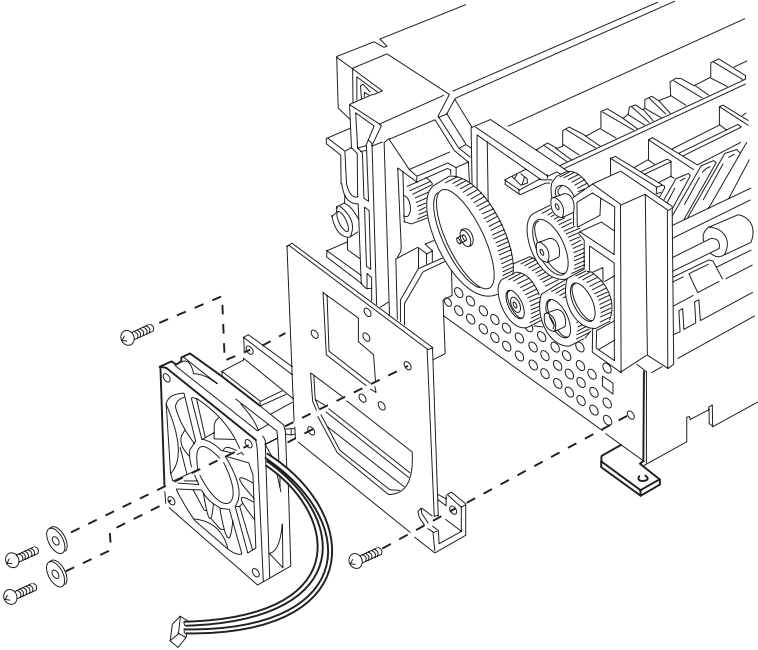

Installation Note: Install the fan so the air flow arrow is to the outside.

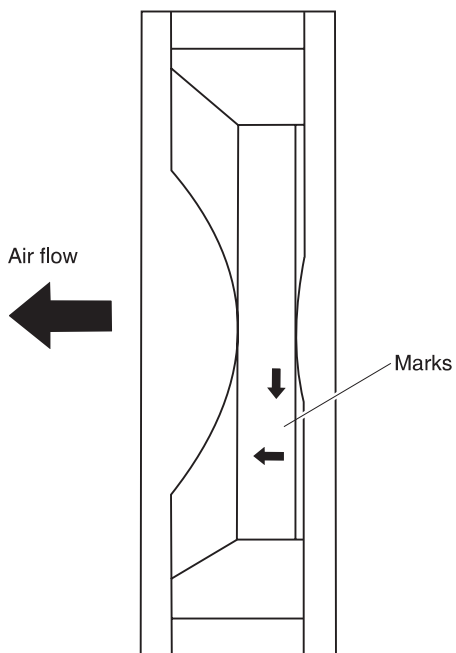

Separator Assembly Removal

1. Remove the paper tray.
2. Place the paper tray upside down, push in the two separator assembly latches, and remove the separator assembly. Be careful not to lose the spring.

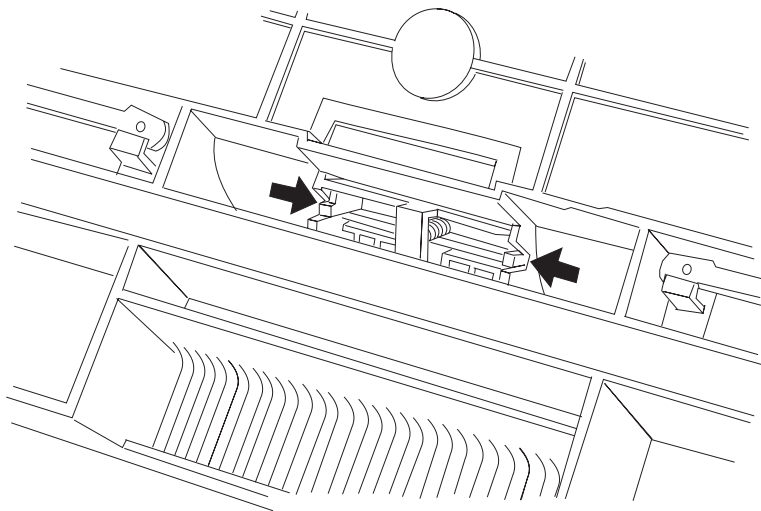

Installation Note: Be sure to install the separator so the rubber surface is toward the front of the drawer. Paper will not feed if the separator is not installed correctly.

Stacker Full Sensor Board Removal

1. Remove the upper cover.
2. Remove the cable from the stacker-full sensor.
3. Remove the board (1 screw).

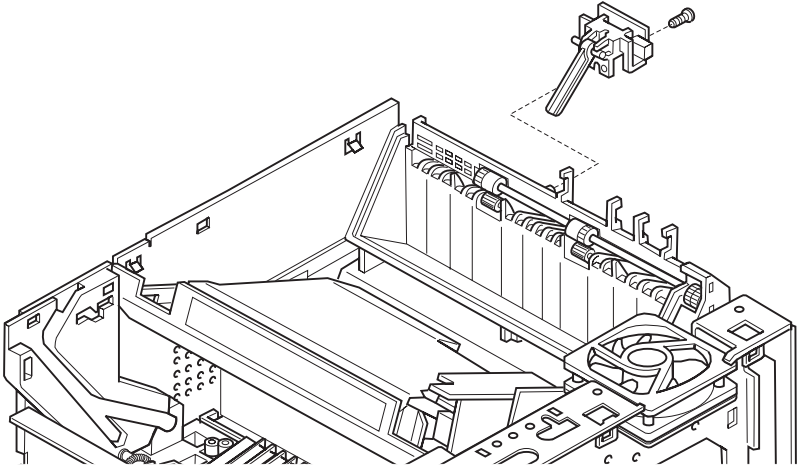

Transfer Corona Removal

Be careful, the parts could be hot.

1. Open the upper door.
2. Remove the print assembly.
3. Use a screwdriver to remove the transfer corona holding block at the left side of the transfer corona.
4. Open the latch on the left side of the base frame and use a screwdriver to lift the left side of the transfer corona then pull it toward the left side. Be careful not to break the wire.

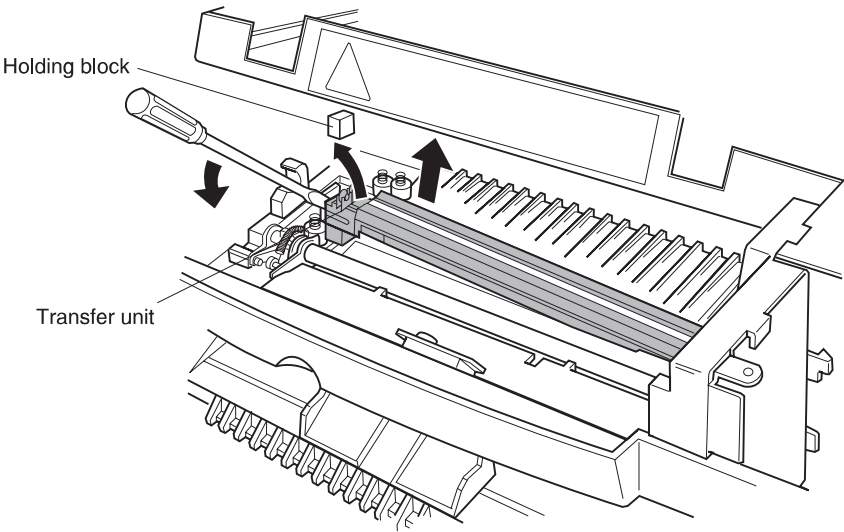

5. Locations

Front and Right Side of Printer

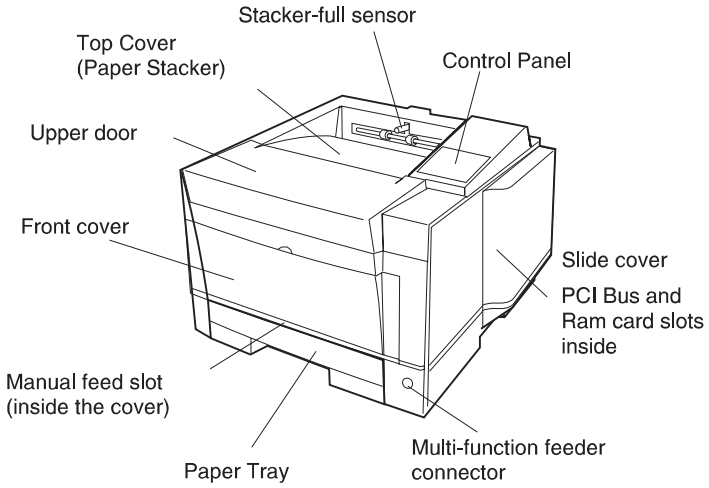

Rear and Left Side of Printer

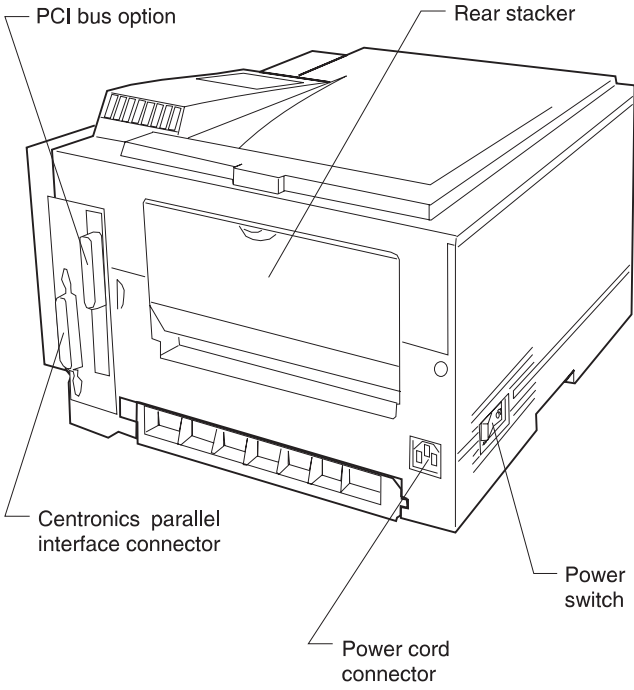

Interior of Printer with Upper Door Open

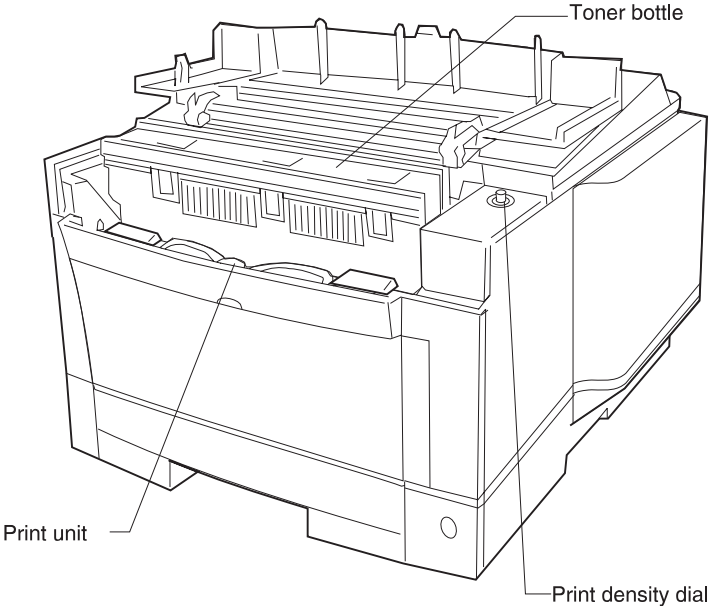

Optional Multi-Function Feeder and Paper Feeder

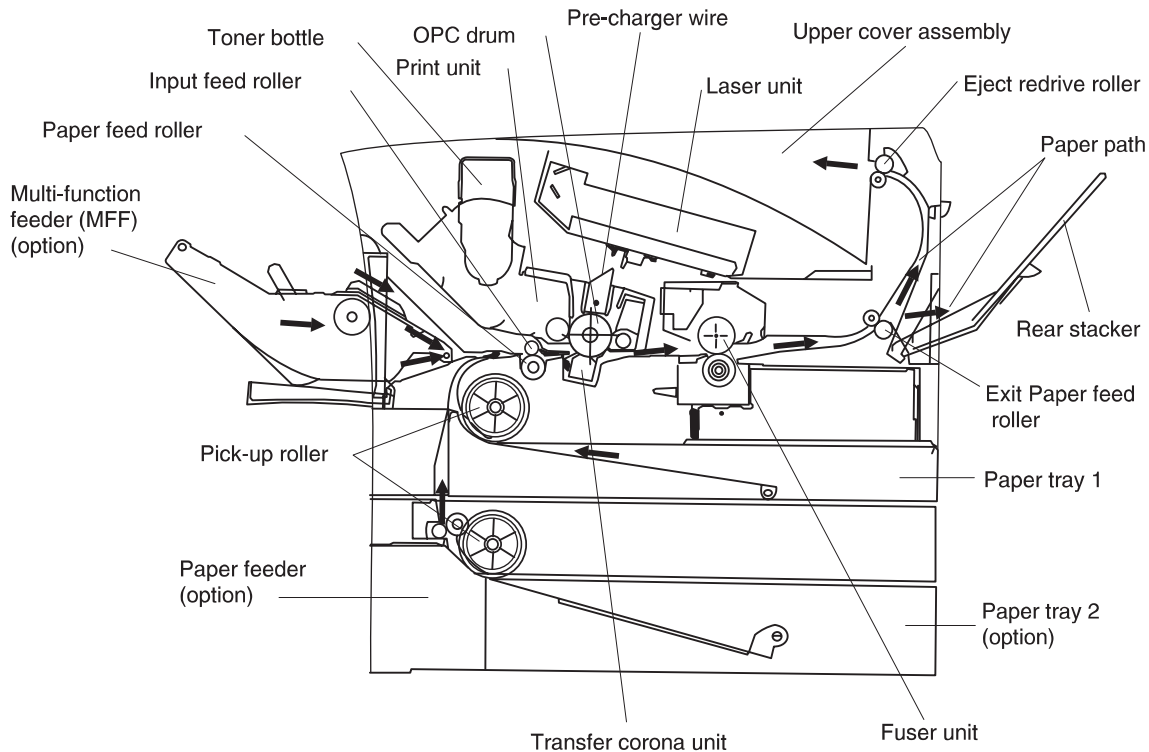

Sensors

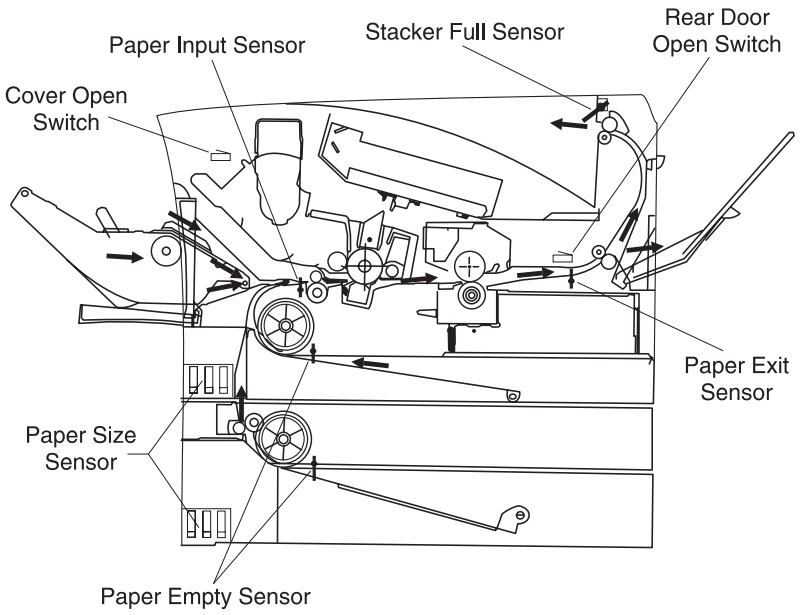

EP Diagram

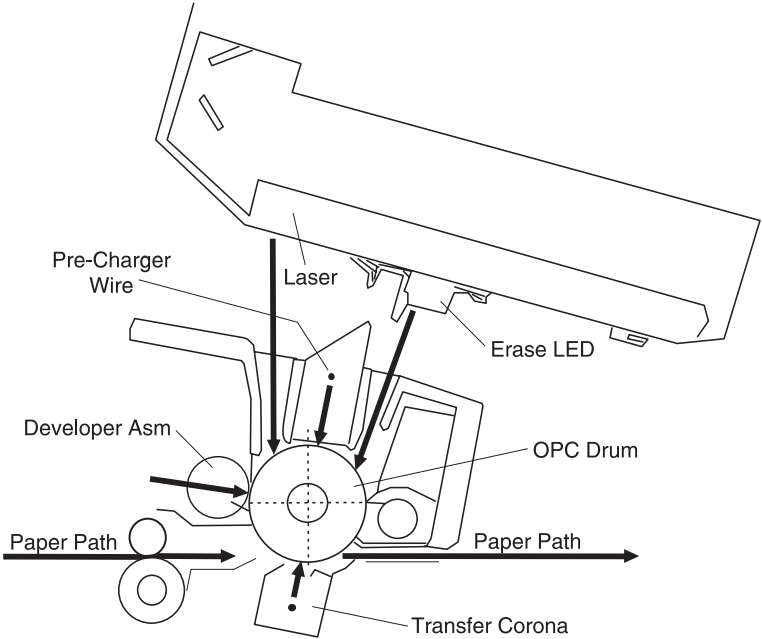

Engine Board

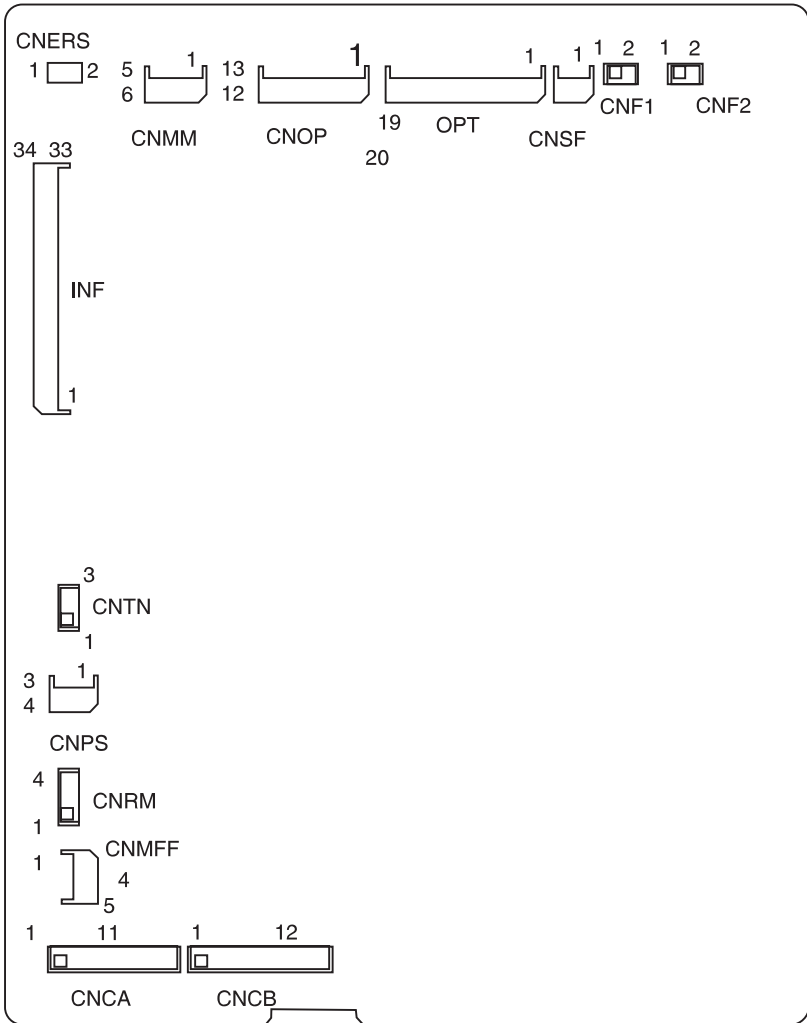

Control Board

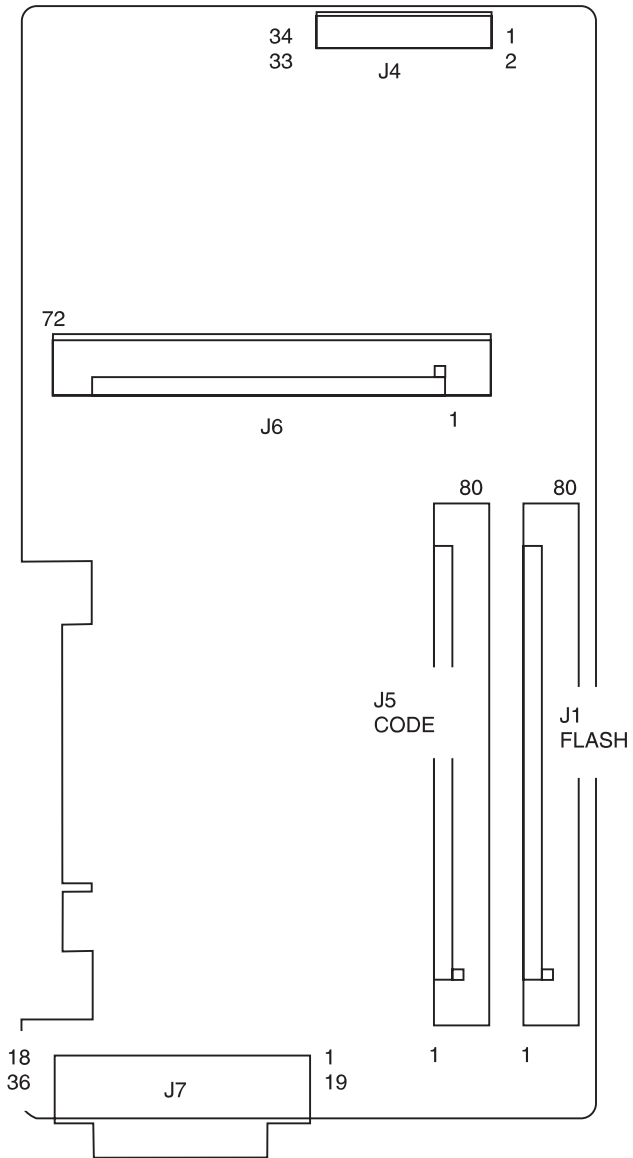

Power Supply Board

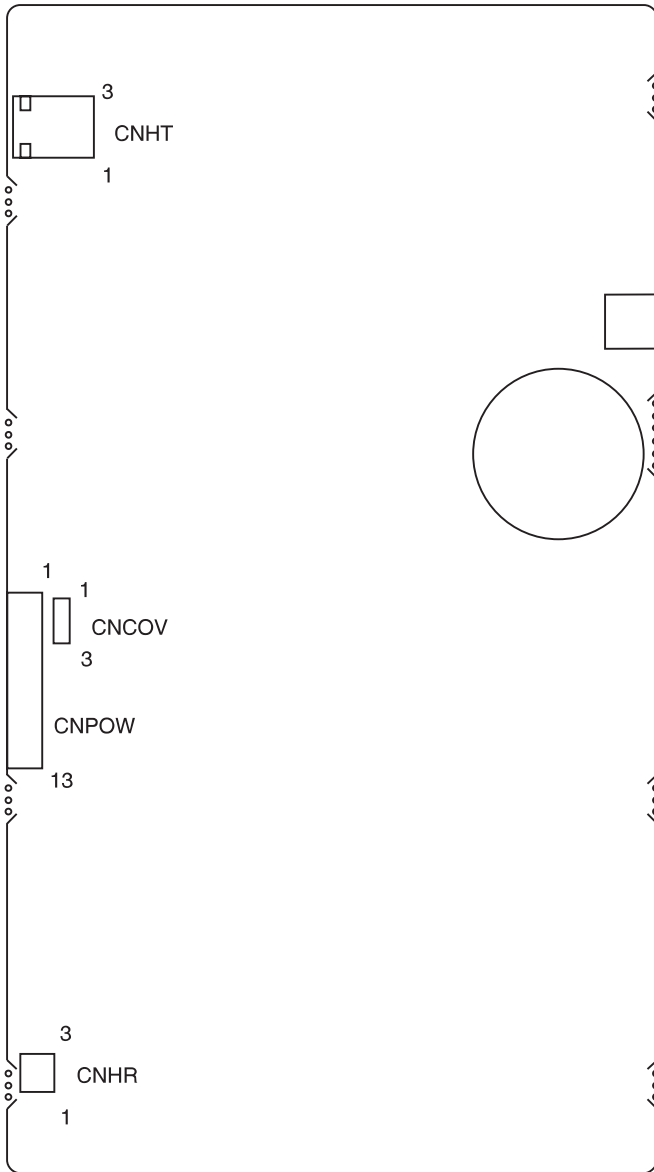

Interconnect Board

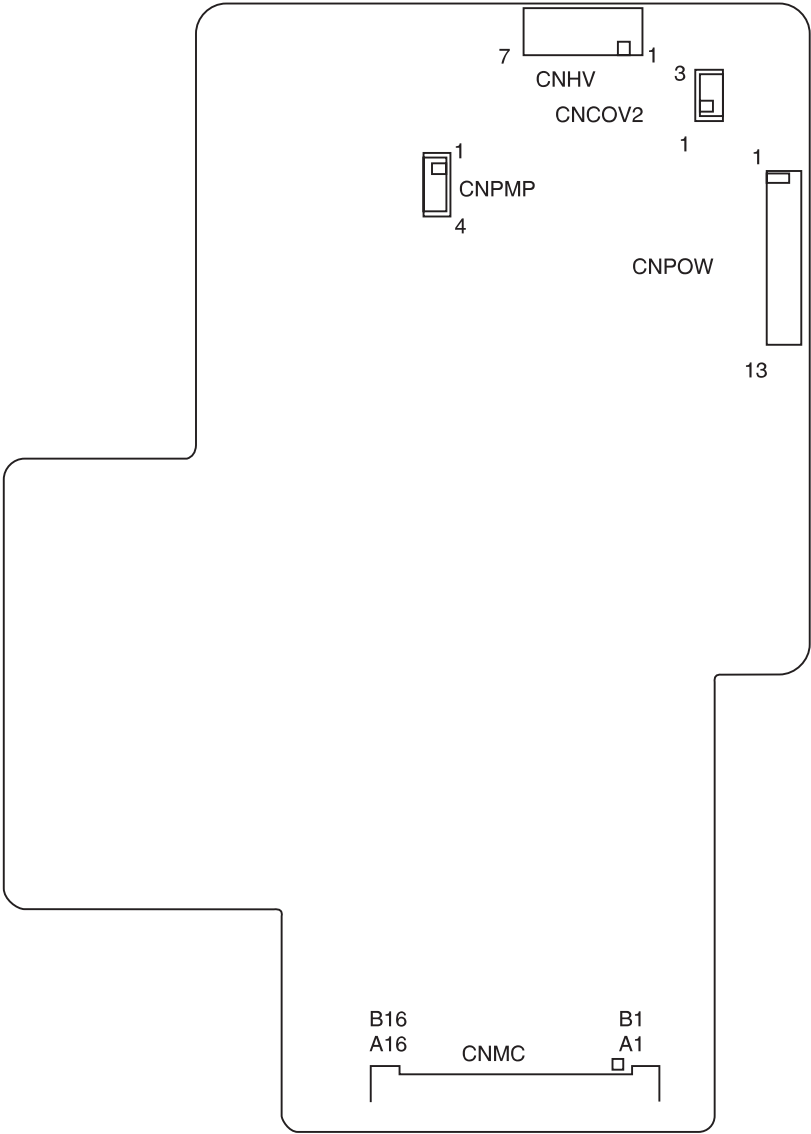

6. Parts Catalog

How to Use This Parts Catalog

- **SIMILAR ASSEMBLIES:** If two assemblies contain a majority of identical parts, they are broken down on the same list. Common parts are shown by one index number. Parts peculiar to one or the other of the assemblies are listed separately and identified by description.
- **AR:** (As Required) in the Units column indicates that the quantity is not the same for all machines.
- **NP:** (Non-Procurable) in the Units column indicates that the part is non-procurable and that the individual parts or the next higher assembly should be ordered.
- **NR:** (Not Recommended) in the Units column indicates that the part is procurable but not recommended for field replacement, and that the next higher assembly should be ordered.
- **R:** (Restricted) in the Units column indicates that the part has a restricted availability.
- **NS:** (Not Shown) in the Asm-Index column indicates that the part is procurable but is not pictured in the illustration.
- **PP:** (Parts Packet) in the Description column indicates that the part is contained in a parts packet.
- A part reference within a circle indicates an assembly or a bill-of-material. An assembly is complete. A bill-of-material contains unassembled parts.
- **INDENTURE:** The indenture is marked by a series of dots located before the parts description. The indenture indicates the relationship of a part to the next higher assembly. For example:

INDENTURE RELATIONSHIP OF PARTS

(No dot) MAIN ASSEMBLY

(One dot) • Detail part or subassembly of a main assembly

(Two dot) •• Detail part or subassembly of a one-dot subassembly

Assembly 1: Upper Cover

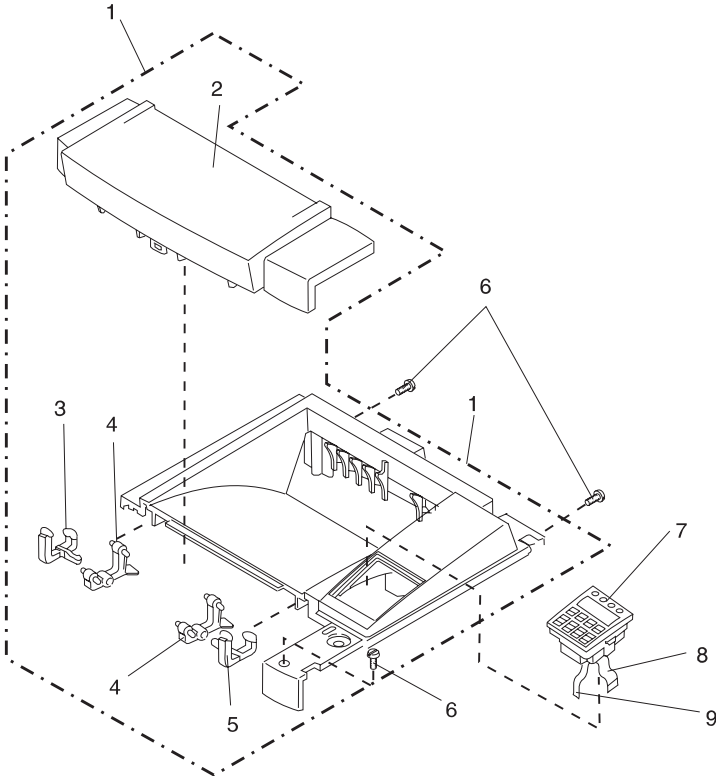

Ref	Part Number	Units	Description
1-1	11A4200	1	Cover Assembly, Top
-2	11A4202	1	Door, Top Cover
-3	11A4203	1	Hinge, Door, Outer Left
-4	11A4204	2	Hinge, Door, Inner
-5	11A4205	1	Hinge, Door, Outer Right
-6		3	Screw, PP 12A4039
-7	11A4208	1	Control Panel with English Overlay
-7	11A4209	1	Control Panel Overlay, W.T. Kit
-8	11A4210	1	Cable, Operator Panel
-9	11A4211	1	Cable, Print Density

Assembly 2: Covers

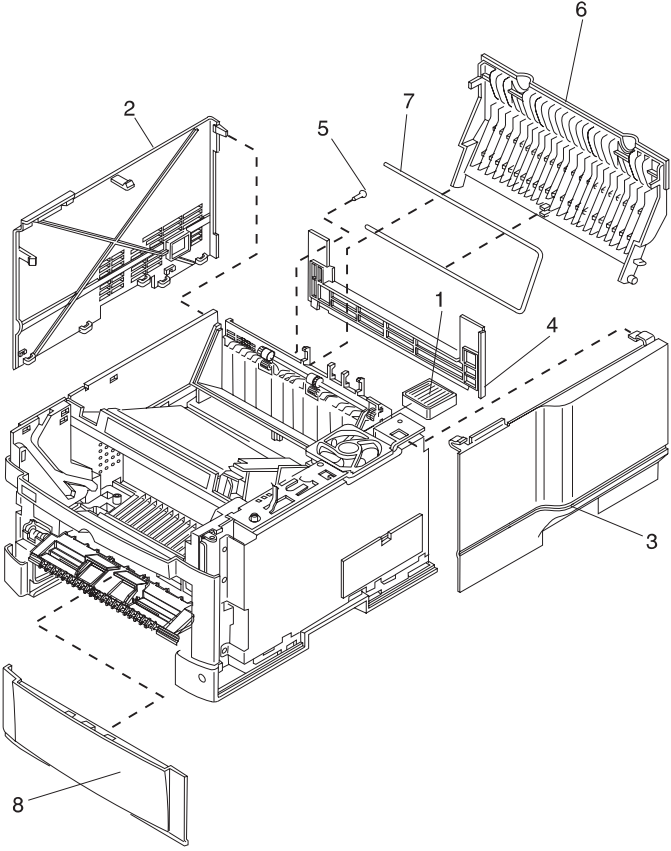

Ref	Part Number	Units	Description
2-1	11A4207	1	Filter, Ozone, Top Cover
-2	11A4212	1	Cover, Left
-3	11A4213	1	Cover, Right
-4	11A4214	1	Cover, Rear, Center
-5		1	Screw, PP 12A4039
-6	11A4215	1	Stacker, Rear
-7	11A4216	1	Guide, Rear Stacker
-8	11A4218	1	Cover, Lower Front

Assembly 3: Electronics

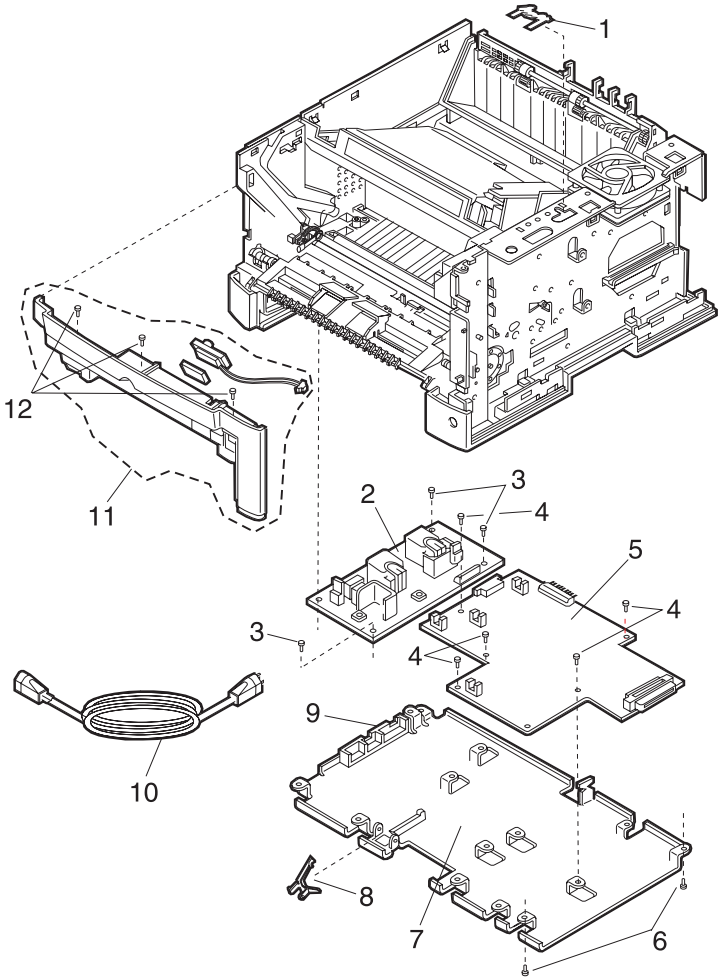

Ref	Part Number	Units	Description
3-1	11A4305	1	Plate, Ground
-2	11A4316	1	Board, High Voltage
-3		3	Screw, PP 12A4039
-4		5	Screw, PP 12A4039
-5	11A4324	1	Board, Interconnect
-6		4	Screw, PP 12A4039
-7	11A4294	1	Cover, Board Access
-8	11A4307	1	Lever, Paper Present Sensor
-9	11A4312	1	Guide, High Voltage Cover
-10	1339526	1	Power Cord, U.S, Canada, A.P. (LV), Bolivia, Columbia, Costa Rica, Ecuador, El Salvador, Guatemala, Honduras, Nicaragua, Panama, Peru, Venezuela, Brazil (LV/HV), Mexico
-10	1339520	1	Austria, Germany, Belgium, France, Netherlands, Norway, Spain, Finland, Turkey, Iceland, Eastern Countries, Greece, Portugal
-10	1339525	1	Denmark
-10	1339524	1	Italy
-10	1339522	1	Switzerland
-10	1339519	1	U.K, Ireland, (VAE), Bahrain, Qatar, Jordan, Oman, Iraq, Kuwait, Yemen, Egypt, Sudan
-10	1339521	1	Israel
-10	1339517	1	Saudi Arabia
-10	1339523	1	South Africa
-10	1342534	1	Chile
-10	1342536	1	Argentina, Paraguay, Uruguay
-11	11A4219	1	Cover Assembly, Upper Front, W/Toner Sensor
-12		3	Screw, PP 12A4039

Assembly 3: Electronics (cont)

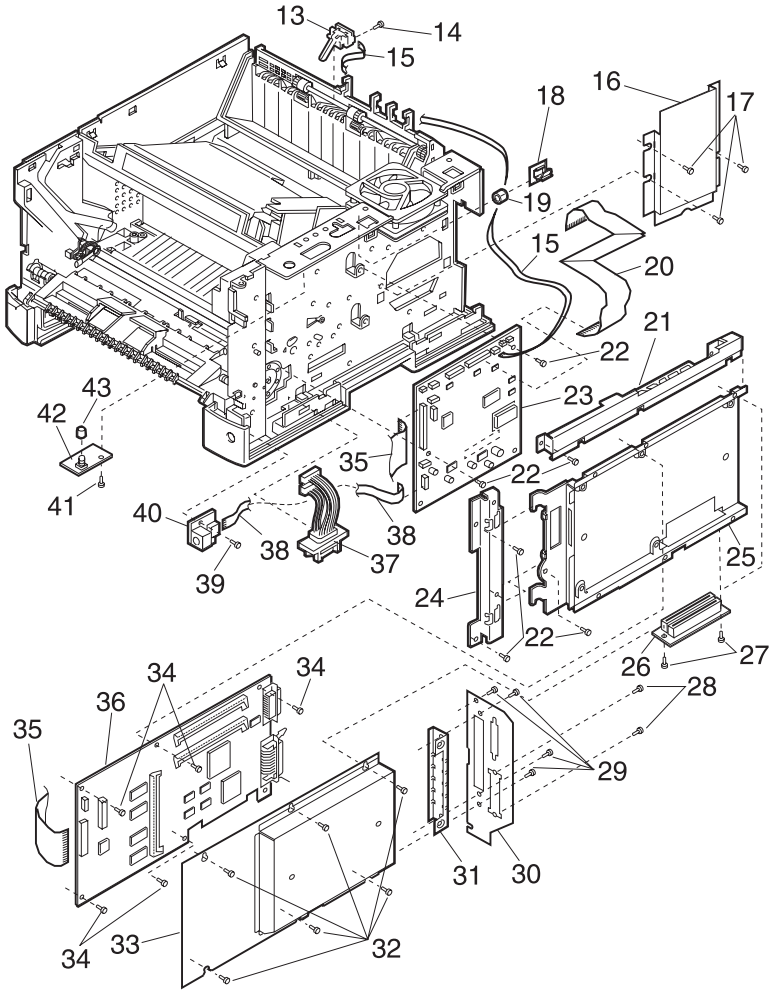

Ref	Part Number	Units	Description
-13	11A4335	1	Sensor Assembly, Stacker Full
-14		1	Screw, PP 12A4039
-15	11A4340	1	Cable, SFS
-16	12A4043	1	Baffle, Cooling Fan
-17		3	Screw, PP 12A4039
-18	11A4304	1	Clamp
-19	11A4283	1	Toroid
-20	11A4333	1	Cable, Printhead
-21	11A4349	1	Plate, Fan Shield
-22		6	Screw, PP 12A4039
-23	11A4332	1	Board, Engine
-24	11A4347	1	Bracket, Fixed Hinge
-25	11A4330	1	Shield Assembly (Inner), With Insulators
-26	12A4041	1	Card Assembly, PCI Bus Interconnect
-27		2	Screw, PP 12A4039
-28		2	Screw, PP 99A0426
-29		2	Screw, PP 12A4039
-30	11A4341	1	Cover, Back Connector Panel
-31	99A0236	1	Cover, INA Blank
-32		6	Screw, PP 12A4039
-33	11A4401	1	Shield Assembly (Outer)
-34		5	Screw, PP 12A4039
-35	12A4035	1	Cable, Control to Engine
-36	11A4337	1	Board, Control, With Cable
-37	11A4334	1	Cable, Lower Control Board
-38	11A4328	1	Cable, MFF
-39		1	Screw, PP 12A4039
-40	11A4327	1	Board, MFF
-41		1	Screw, PP 12A4039
-42	11A4325	1	Board, Print Density
-43	11A4326	1	Knob, Density Board Control

Assembly 4: Frame, Left Side

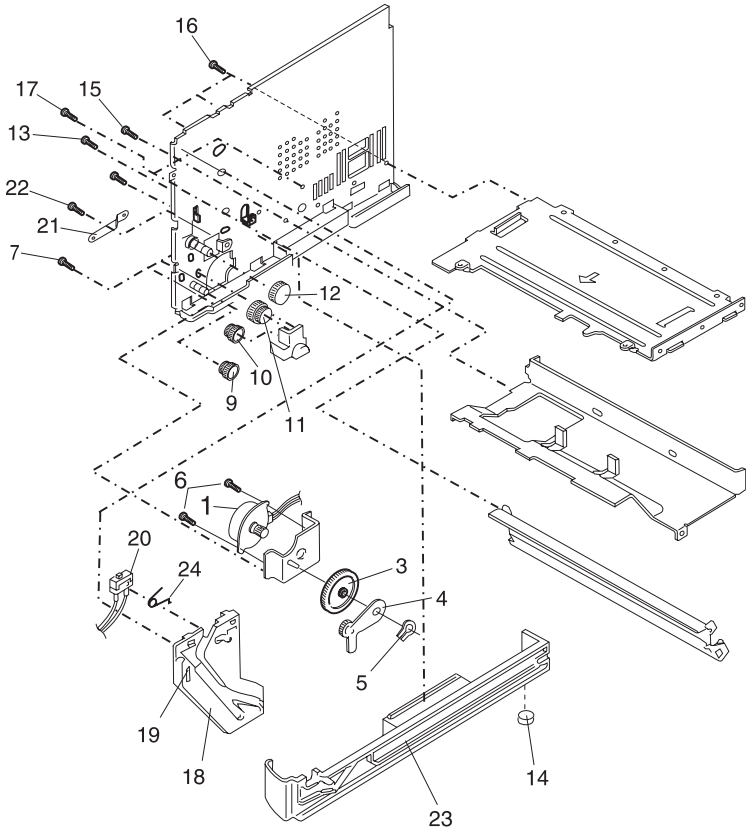

Ref	Part Number	Units	Description
4-1	12A4047	1	Motor, Pick
-3		1	Gear Pick Motor, PP 12A4036
-4		1	Gear Assembly, MFF, A, PP 12A4036
-5	11A4345	1	Clip
-6		2	Screw, PP 12A4039
-7		3	Screw, PP 12A4039
-9		1	Gear, MFF, B, PP 12A4036
-10		1	Gear, MFF, C, PP 12A4036
-11		1	Gear, MFF, D, PP 12A4036
-12		1	Gear, MFF, E, PP 12A4036
-13		2	Screw, PP 12A4039
-14	11A4348	1	Foot, Rubber
-15		3	Screw, PP 12A4039,
-16		3	Screw, PP 12A4039
-17		2	Screw, PP 12A4039
-18	11A4418	1	Guide, Print Unit, Left
-19	11A4419	1	Label, Print Unit, Left Install
-20	11A4423	1	Switch, Cover Open
-21	11A4400	1	Plate, Ground
-22		1	Screw, PP 12A4039
-23	11A4313	1	Guide Assembly, Paper Tray, Left
-24	12A4046	1	Spring, Cover Open Switch

Assembly 5: Frame, Right Side

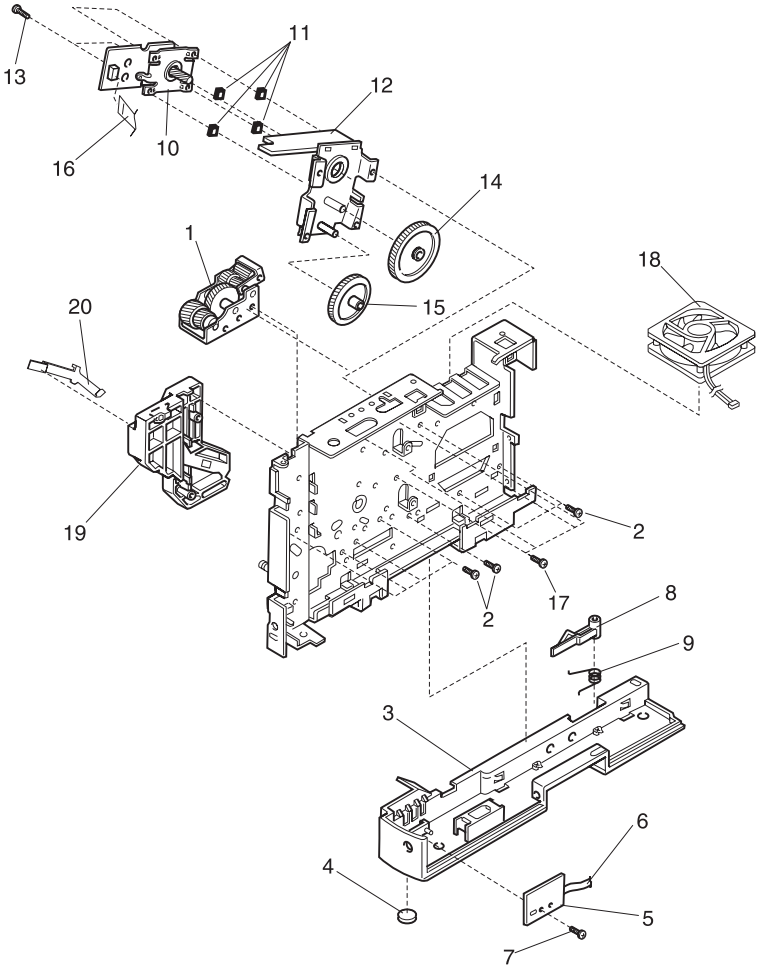

Ref	Part Number	Units	Description
5-1	11A4402	1	Gear Box Assembly, Main Motor
-2		8	Screw, PP 12A4039
-3	11A4235	1	Guide Assembly, Paper Tray, Right
-4	11A4348	1	Foot, Rubber
-5	11A4405	1	Board, Paper Size Sensor
-6	11A4406	1	Cable, Paper Size Sensor
-7		1	Screw, PP 12A4039
-8	11A4407	1	Lever, Paper Tray Lock
-9	11A4408	1	Spring
-10	11A4410	1	Motor, Main
-11	11A4411	4	Damper, Main Motor
-12	11A4412	1	Bracket Assembly, Main Motor
-13		4	Screw, PP 12A4039
-14		1	Gear, Main Motor, #MA, PP 12A4036
-15		1	Gear, Main Motor, #MB, PP 12A4036
-16	11A4413	1	Cable, Main Motor
-17		4	Screw, PP 12A4039
-18	11A4414	1	Fan, Engine Cooling
-19	12A4044	1	Guide, Print Unit Right
-20	11A4417	1	Plate, Ground, Right

Assembly 6: Input Paper Feed

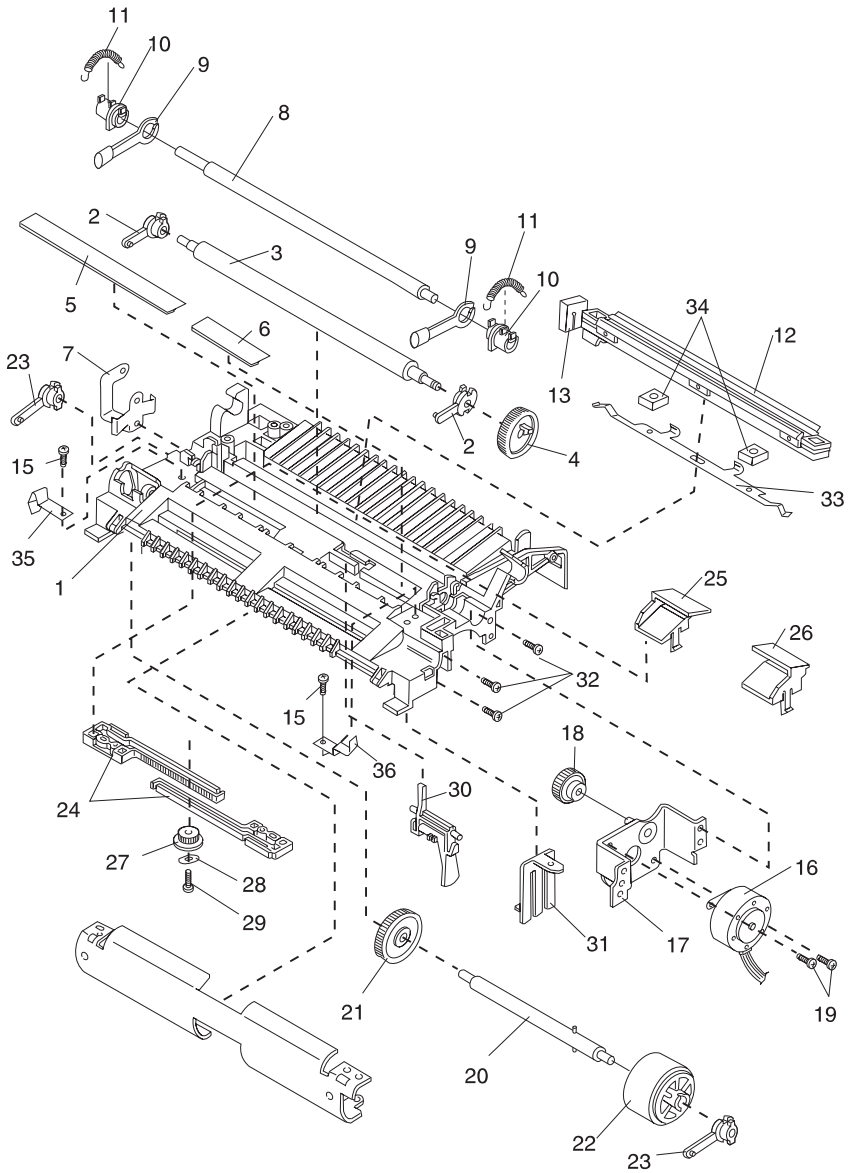

Ref	Part Number	Units	Description
6-1	11A4268	1	Frame, Paper Feed
-2	11A4271	2	Bearing, Feed Roll
-3	11A4269	1	Feed Roll, Lower
-4		1	• Gear, Feed Roll, PP 12A4038
-5	11A4272	1	• Strip, Mylar, Left Guide
-6	11A4273	1	• Strip, Mylar, Right Guide
-7	11A4274	1	Terminal, Left Paper Feed Ground
-8	11A4276	1	Feed Roll, Upper
-9	11A4277	2	Lever. Lock
-10	11A4278	2	Bearing
-11	11A4279	2	Spring
-12	11A4280	1	Corona, Transfer
-13	11A4281	1	Left Stop, Transfer Corona
-14	11A4282	1	Guide, Paper, Front
-15		2	Screw, PP 12A4039
-16	12A4047	1	Motor, Paperfeed
-17	11A4285	1	Bracket, Pick Motor Mount
-18		1	Gear, Pick Motor, PP 12A4038
-19		2	Screw, PP 12A4039
-20	11A4286	1	Shaft Assembly, Pick Roller
-21		1	Gear, Pick Roller, PP 12A4038
-22	11A4287	1	Pick Roller
-23	11A4271	2	Bearing, Pick Roller
-24	11A4289	1	Rack, Paper Feed Guide
-25	11A4290	1	Guide, Paper, Left
-26	11A4291	1	Guide, Paper, Right
-27	11A4292	1	Gear, Paper Feed Guide Rack
-28	11A4293	1	Washer
-29		1	Screw, PP 12A4039
-30	11A4295	1	Flag, Paper Entry Sensor
-31	11A4296	1	Lever, Multi-Switch
-32		3	Screw, PP 12A4039
-33	11A4220	1	Terminal, Ground, Corona
-34	11A4226	2	Stop, Transfer Corona, Lower
-35	11A4227	1	Terminal, Ground, Paper Feed, Left
-36	11A4270	1	Ground, Paper Feed, Right

Assembly 7: Printhead and Paper Feed Redrive

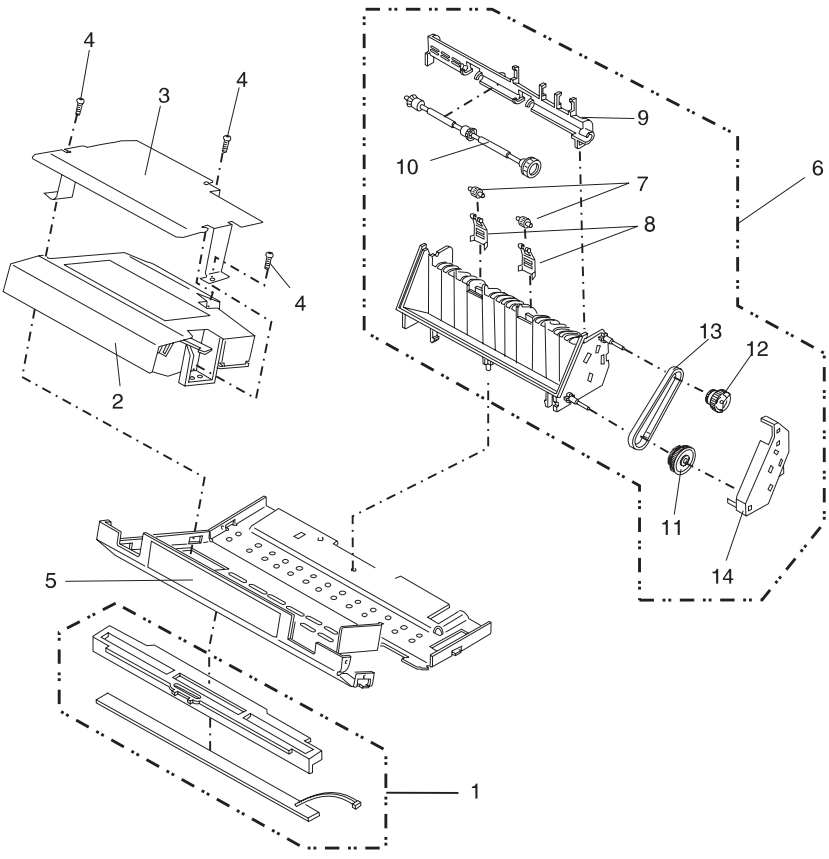

Ref	Part Number	Units	Description
7-1	11A4225	1	LED, Printhead Erase
-2	11A4228	1	Printhead
-3	11A4229	1	Cover
-4		3	Screw, PP 12A4039
-5	11A4231	1	Label, Caution
-6	11A4311	1	Paper Feed Redrive Exit Assembly
-7	11A4314	2	Roller, Redrive
-8	11A4315	2	Holder, Roller
-9	11A4317	1	Guide, Roller
-10	11A4300	1	Roller Assembly
-11		1	Gear, #6 (Lower), PP 12A4038
-12		1	Gear, #7 (upper), PP 12A4038
-13	11A4319	1	Belt, Timing
-14	11A4320	1	Cover, Gear

Assembly 8: Exit Paper Feed Frame

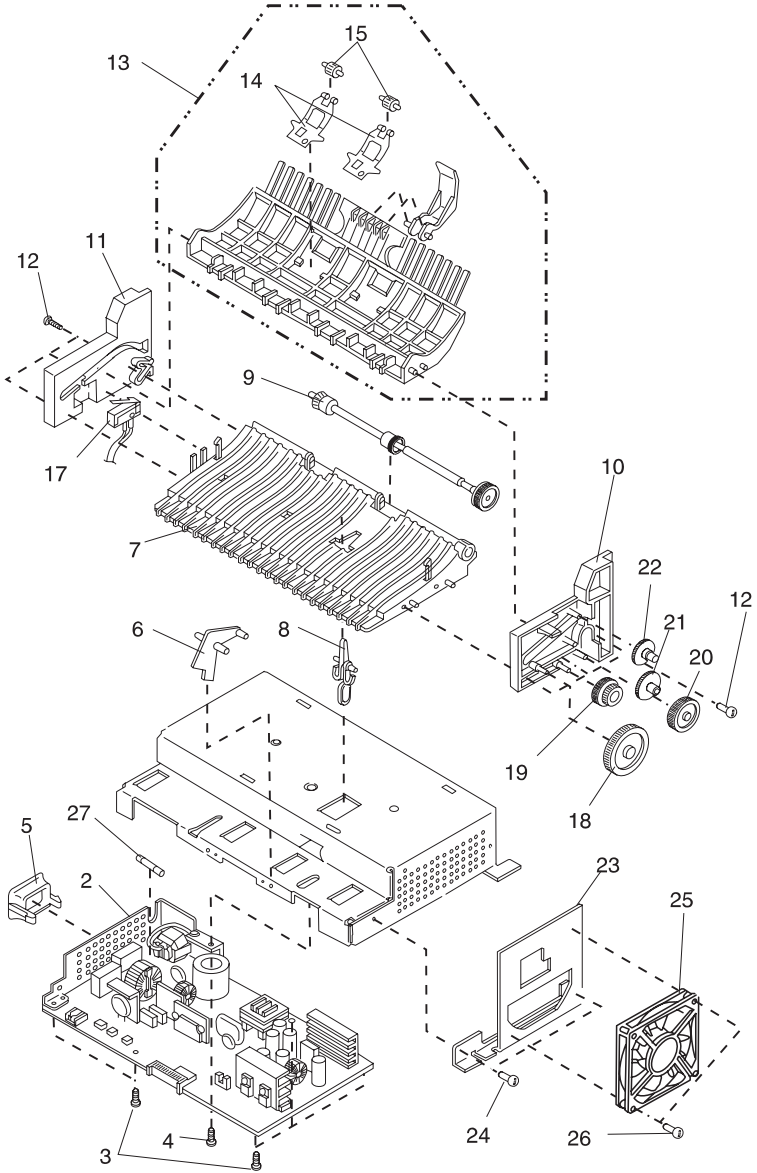

Ref	Part Number	Units	Description
8-2	11A4234	1	Board, Power Supply, 100-120 V
-2	11A4236	1	Board, Power Supply, 220-240 V
-3		5	Screw, PP 12A4039
-4		1	Screw, PP 12A4039
-5	11A4253	1	Cover, Power Supply Switch
-6	11A4254	1	Lever, Exit Sensor
-7	11A4298	1	Frame, Center
-8	11A4299	1	Sensor, Exit Paper Feed
-9	11A4300	1	Roller Assembly, Exit Paper Feed
-10	11A4301	1	Frame, Right Side
-11	11A4302	1	Frame, Left Side
-12		6	Screw, PP 12A4039
-13	11A4303	1	Guide Assembly
-14	11A4306	2	Holder, Guide Roller
-15	11A4314	2	Roller, Guide
-17	11A4310	1	Switch Assembly
-18		1	Gear, #1, PP 12A4038
-19		1	Gear, #2, PP 12A4038
-20		1	Gear, #3, PP 12A4038
-21		1	Gear, #4, PP 12A4038
-22		1	Gear, #5, PP 12A4038
-23	11A4255	1	Bracket, Fuser Cooling Fan
-24		2	Screw, PP 12A4039
-25	11A4288	1	Fan, Process Cooling
-26		2	Screw, 12A4039
-27	12A4033	1	Fuse, 125V, 10A
-27	12A4034	1	Fuse, 250V, 5.3A

Assembly 9: Fuser

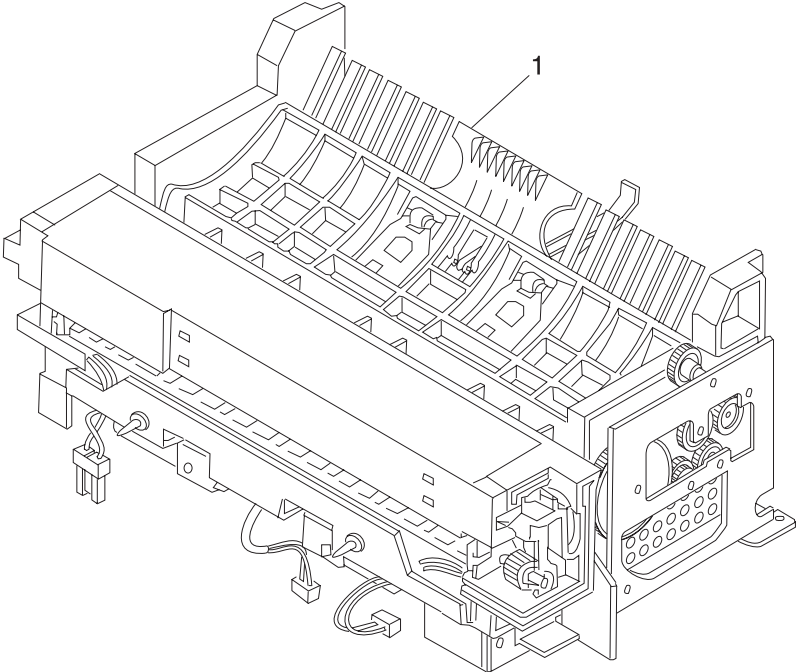

Ref	Part Number	Units	Description
9-1	11A4321	1	Fuser Assembly, 100-120 V
-1	11A4322	1	Fuser Assembly, 220-240 V

Assembly 10: Paper Tray, 250 Sheet

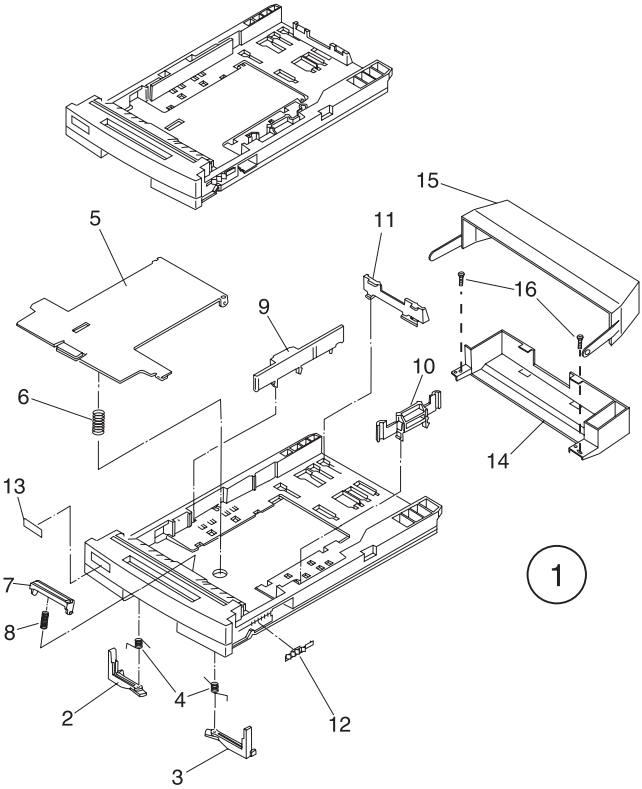

Ref	Part Number	Units	Description
10-1	12A4028	1	Tray Assembly
-2	12A4001	1	Holder, Paper Lift Plate, Left
-3	12A4002	1	Holder, Paper Lift Plate, Right
-4		2	Spring, Lift Plate Holder, PP 12A4037
-5	12A4003	1	Plate, Paper Lift
-6		1	Spring, Paper Tray Lift Plate, PP 12A4037
-7	12A4004	1	Separator, Paper
-8		1	Spring, PP 12A4037
-9	12A4005	1	Guide, Paper, Left
-10	12A4006	1	Guide, Paper, Right
-11	12A4007	1	Guide, Paper, End
-12	12A4019	1	Lever, Paper Size
-13	11A4232	1	Label, Size Packet
-14	12A4030	1	Extender, 250 Sheet, Legal
-15	12A4032	1	Dust Cover, Rear
-16		2	Screw, PP 12A4039

Assembly 11: Optional 450 Sheet Second Paper Tray

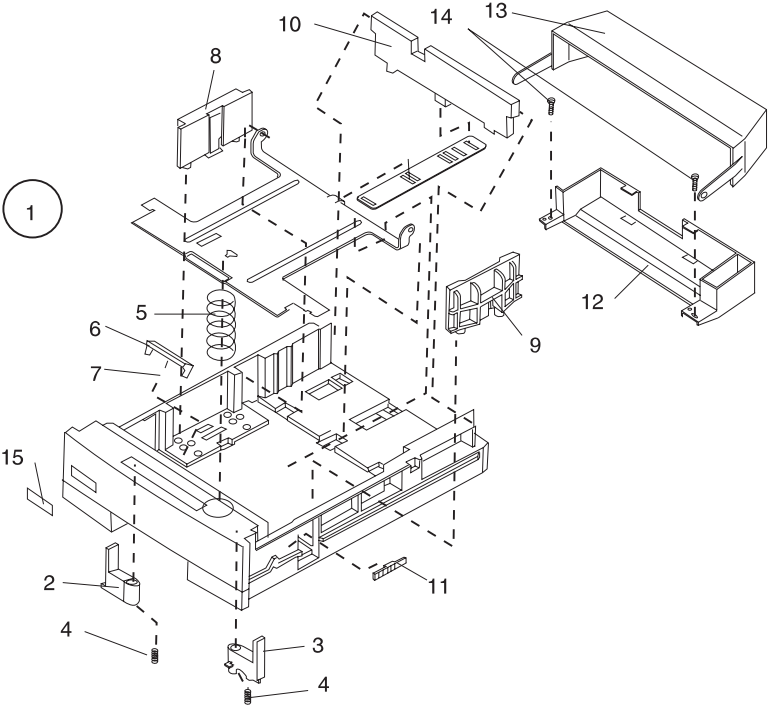

Ref	Part Number	Units	Description
11-1	12A4029	1	Tray Assembly, 450 Sheet
-2	12A4011	1	Holder, Plate, Left
-3	12A4012	1	Holder, Plate, Right
-4		2	Spring, PP 12A4037
-5		1	Spring, PP 12A4037
-6	12A4014	1	Separator, Paper
-7		1	Spring, PP 12A4037
-8	12A4015	1	Guide, Paper, Left
-9	12A4016	1	Guide, Paper, Right
-10	12A4017	1	Guide, Paper, End
-11	12A4019	1	Lever, Paper Size
-12	12A4031	1	Extender, 450 Sheet, Legal
-13	12A4032	1	Dust Cover, Rear
-14		2	Screw, PP 12A4039
-15	11A4232	1	Label, Size Packet

Assembly 12: Optional 450 Sheet Second Paper Drawer (2)

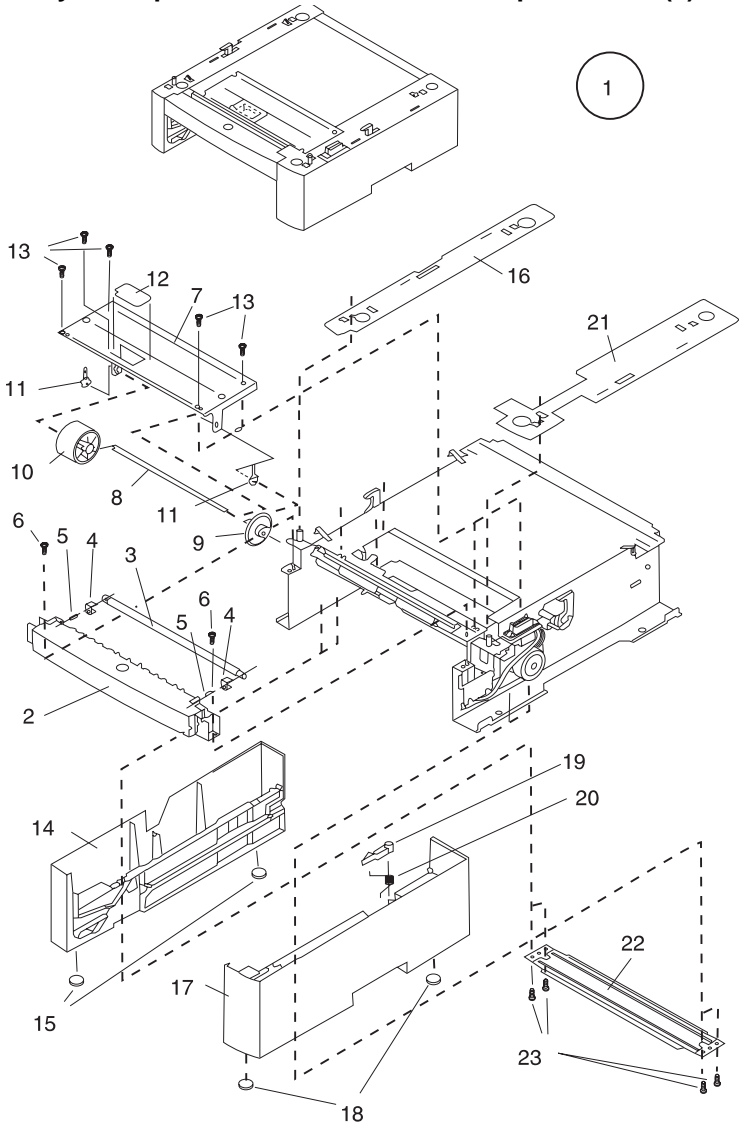

Ref	Part Number	Units	Description
12-1	12A4025	1	Drawer, 450 Sheet Feeder, without Tray
-2	12A4026	1	Frame, Front
-3	12A4027	1	Roller, Redrive Backup
-4	11A4323	2	Bushing, Redrive, Backup Roller
-5	11A4329	2	Spring
-6		2	Screw, PP 12A4039
-7	11A4221	1	Bracket, Pick Roller
-8	11A4331	1	Shaft, Pick Roller
-9	11A4224	1	Gear, Pick Roller
-10	11A4287	1	Roller, Pick
-11	11A4404	2	Bearing, Roller
-12	11A4336	1	Protector, Pick Roller
-13		5	Screw, PP 12A4039
-14	11A4339	1	Cover, 450 Sheet, Left Side
-15	11A4348	2	Foot, Rubber
-16	11A4403	1	Cover, Top Left
-17	11A4342	1	Cover, Right Side
-18	11A4348	2	Foot, Rubber
-19	11A4407	1	Lever, Paper Tray Lock
-20	11A4408	1	Spring
-21	11A4409	1	Cover, Top Right
-22	11A4420	1	Plate, Lower Paper Tray Guide
-23		4	Screw, PP 12A4039

Assembly 13: Optional 450 Sheet Second Paper Drawer (2)

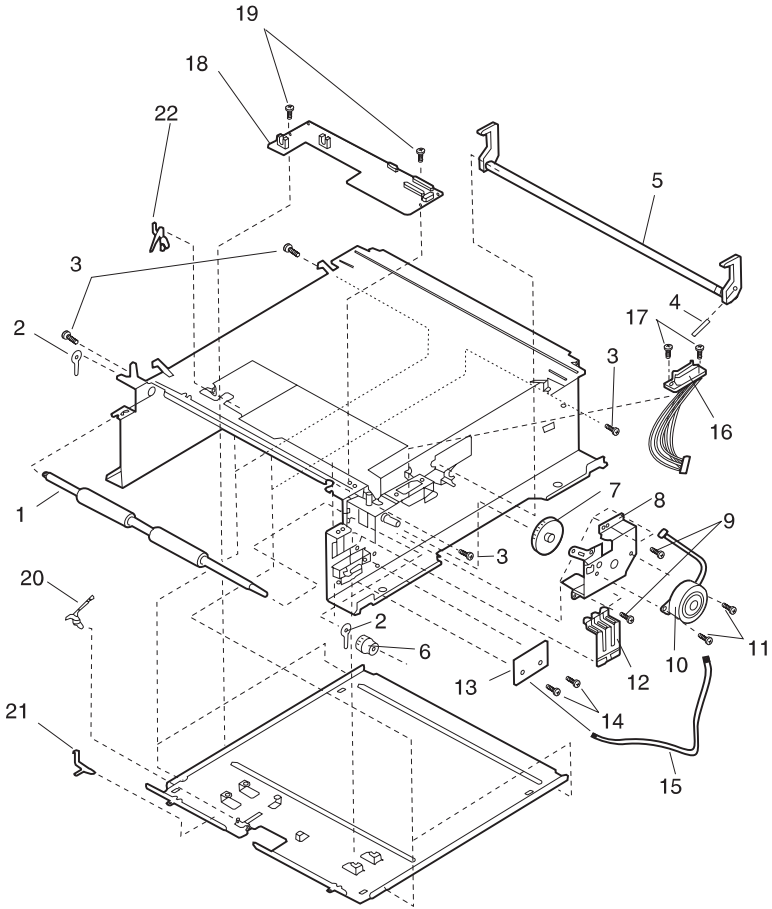

Ref	Part Number	Units	Description
13 -1	11A4421	1	Roller, Redrive
-2	11A4404	2	Bearing, Roller
-3		4	Screw, PP 12A4039
-4	12A4424	1	Spring
-5	12A4000	1	Lever, Lock
-6	12A4009	1	Gear, Redrive
-7	12A4010	1	Gear, Idler
-8	12A4013	1	Bracket, Motor Mounting
-9		4	Screw, PP 12A4039
-10	12A4018	1	Motor, Pick
-11		2	Screw, PP 12A4039
-12	12A4020	1	Lever, Multi-switch
-13	11A4223	1	Board, Paper Size Sensor
-14		2	Screw, PP 12A4039
-15	11A4406	1	Cable, Paper Size Sensor
-16	11A4338	1	Cable, Drawer Interconnect
-17		2	Screw, PP 12A4039
-18	11A4422	1	Board, Driver
-19		2	Screw, PP 12A4039
-20	12A4021	1	Lever, Sensor, FP
-21	12A4022	1	Lever, Sensor, FE
- 22	12A4023	1	Lever, Sensor

Assembly 14: Optional Multi-Function Feeder

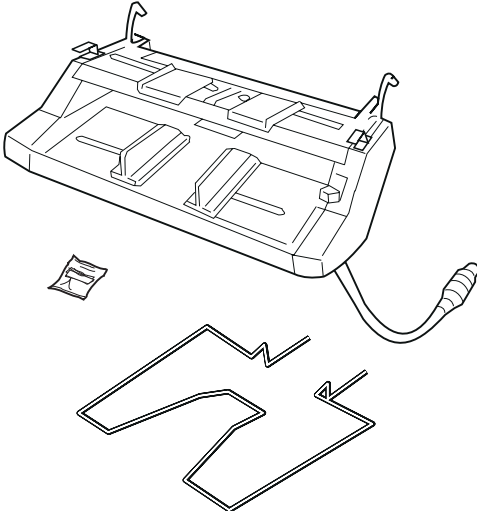

Ref	Part Number	Units	Description
14 -1	12A4024	1	Feeder, Multi-Function

Assembly 15: Options

Ref	Part Number	Units	Description
	12A4024	1	Feeder, Multi-Function
	12A4025	1	Drawer, 450 Sheet Feeder, without Tray
	99A0420	1	Card Assembly, INA, Token Ring
	99A0421	1	Card Assembly, INA, Ethernet 10/100 Base-T
	99A0560	1	Card Assembly, Tri-Port
	99A0515	1	Disk Drive, Hard, without Control Card
	99A0517	1	Memory, 4MB, DRAM
	99A0518	1	Memory, 8MB, DRAM
	99A0519	1	Memory, 16MB, DRAM
	99A0520	1	Memory, 32MB, DRAM
	99A0724	1	Memory, 64MB, DRAM
	99A0521	1	Memory, 1MB, Flash
	99A0522	1	Memory, 2MB, Flash
	99A0523	1	Memory, 4MB, Flash
	99A0424	1	Infrared Adapter
	12A4029	1	Tray Assembly, 450 Sheet
	12A4028	1	Tray Assembly, 250 Sheet
	99A0516	1	Card Asm, Hard Disk Drive
	12A4042	1	SIMM, IPDS Board
	99A0629	1	Adapter, Coax/Twin Adapter for SCS
	13A0296	1	Cable, Twinax
	13A0297	1	Cable, Coax
	99A0545	1	Adapter, Serial Port
	99A0422	1	Card Assembly, INA, Ethernet 10 Base 2/10 Base T

Assembly 16: Miscellaneous

Ref	Part Number	Units	Description
	12A4036	1	Parts Packet, Left/Right Frame Gears
	12A4037	1	Parts Packet, Paper Tray Springs
	12A4038	1	Parts Packet, Paper Feed Gears
	12A4039	1	Parts Packet, Screws
	99A0426	1	Parts Packet, Parallel Connector Mounting Screws
	7350166	1	Packaging, Printer
	12A4040	1	Tool, Wire Cleaning

Index

A

abbreviations 1-2

B

base sensor test 3-11

button test 3-6

C

control board 5-8

control board removal 4-12

cover open switch service check
2-9

cover-open switch removal 4-7

covers assembly 6-4

D

dead machine service check 2-10

diagnostic aids 3-1

diagnostic information 2-1

diagnostic mode 3-1

disabling download emultaions 3-4

disk test/clean 3-3

DRAM memory test 3-6

E

electronics parts 6-6

engine board 5-7

engine board removal 4-8

engine fan removal 4-9

engine fan service check 2-11

EP diagram 5-6

erase LED service check 2-11

error log 3-4

exit paper feed frame assembly
6-18

exit paper feed roller assembly
removal 4-10

exit sensor service check 2-12

exiting the diagnostics mode 3-1

F

flash test 3-3

frame assembly, left side 6-10

frame assembly, right side 6-12

front and right side of printer 5-1

fuser assembly 6-20

fuser removal 4-11

fuser service check 2-13

H

hardware tests 3-5

high voltage power supply board
and interconnect board removal
4-12

I

image quality service check 2-13

initial check 2-2

input paper feed assembly 6-14

input sensor service check 2-21

input tray feed test 3-10

input tray sensor test 3-10

input tray tests 3-10

interconnect board 5-10

interior of printer with upper door
open 5-3

L

LCD test 3-5

locations 5-1

M

main motor removal 4-14

maintenance approach 1-1

mechanical operation 1-3

multi-function feeder board removal
4-30

N

notices vii

O

operator panel buttons service
check 2-22

operator panel display service check
2-22

optional multi-function feeder and

- paper feeder 5-4
- optional multi-function feeder
 - assembly 6-30
- optional 450 sheet second paper drawer assembly 6-26, 6-28
- optional 450 sheet second paper tray assembly 6-24
- options 6-32
- options service check 2-23

P

- paper ejection 1-8
- paper feed drive mechanism 1-5
- paper jams - base printer 3-16
- paper jams - options 3-16
- paper tray assembly, 250 sheet 6-22
- paperfeed motor removal 4-17
- paperfeed roller removal 4-18
- parallel wrap test 3-7
- parts catalog 6-1
- parts packets 6-33
- pick-up motor removal 4-22
- pick-up roller removal 4-32
- power on self-test 3-2
- power supply board 5-9
- power supply board removal 4-25
- precautions for disassembly 4-1
- precautions for handling the drum cartridge 4-2
- precautions for handling the laser equipment 4-3
- print density board removal 4-26
- print quality test pages 3-14
- print registration 3-11
- print tests 3-14
- printer operation 1-5
- printer setup 3-12
- printhead 1-7
- printhead and paper feed redrive assembly 6-16
- printhead erase LED assembly removal 4-27
- printhead removal 4-27
- printing menu settings page 3-15
- process drive mechanism 1-7

- process fan removal 4-28
- process fan service check 2-27

Q

- quick disk test 3-2

R

- rear and left side of printer 5-2
- removal procedures 4-4
- ROM memory test 3-6

S

- safety information vii
- sensors 5-5
- separator assembly removal 4-30
- serial port service check 2-27
- serial wrap test 3-8
- service checks 2-9
- service error code table 2-3
- setting configuration ID 3-13
- setting the page count 3-12
- stacker full sensor board removal 4-31
- standard bin full sensor service check 2-27
- start 2-2
- symptom table 2-8
- system diagram 1-4

T

- toner sensor service check 2-29
- tools 1-1
- transfer corona removal 4-32
- transfer corona service check 2-29

U

- upper cover assembly 6-2
- user error messages 2-5

V

- viewing the error log 3-4
- viewing the permanent page count 3-13

Readers Comment Form

You may use this form to communicate your comments about this publication, with the understanding that Lexmark may use or distribute whatever information you supply in any way it believes appropriate without incurring any obligation to you.

1. Did you find the book well organized?

Yes No

2. Was the content of the book accurate and complete?

Yes No

3. Was the book easy to use?

Yes No

4. What can we do to improve the book?

5. What is your job title?

Questions or comments about supplies, service, applications, and so on will slow response time considerably. Please refer those questions or comments to your authorized dealer or point of purchase.

Note: Please direct all requests for copies of publications to your point of purchase. Publications are not stocked at the location to which this form is addressed.

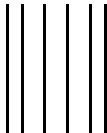

NO POSTAGE
NECESSARY
IF MAILED
IN THE
UNITED STATES

BUSINESS REPLY MAIL

FIRST CLASS MAIL PERMIT NO. 2659 LEXINGTON, KY

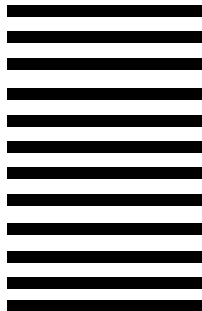

POSTAGE WILL BE PAID BY ADDRESSEE

LEXMARK INTERNATIONAL INC
DEPARTMENT D22A BUILDING 035-3
740 NEW CIRCLE ROAD NW
LEXINGTON KY 40511-9954



Fold Here

Cut Along Line

Tape

Please Do Not Staple

Tape